

LOW POWER BATTERY CHARGER WITH SOLAR PANEL INPUT, THE ELECTRONIC CIRCUIT

Silviu Epure, Emil Roşu

"Dunărea de Jos" University of Galaţi, Romania

Abstract: This paper presents an electronic circuit to be used as interface between a low-power (20W) low voltage (6V) solar panel and a lead-acid Li-Ion 12V battery. A low-cost microcontroller drives a boost circuit, connected between the solar panel and the battery, to maintain the battery in fully charged state as long as possible. All aspects regarding hardware design are presented together with experimental results that confirm the ability of the circuit to perform the task.

Keywords: dc/dc converter, current transducer, board design, microcontroller

1. INTRODUCTION

The use of Photovoltaic (PV) panels as renewable power source is attractive because of the low maintenance costs and the possibility to mount them with minimal hardware parts on the roof of the buildings. The present research is focused on improving the efficiency of the solar cells, so it is expected that the use of PV panel as power sources will increase.

Usually, the renewable power source uses electric batteries to store the produced energy. On long term estimation, it seems that the cost of battery acquisition and maintenance is higher than the actual cost of the solar panels used in the system. A guide to proper selection of the solar panel and battery is presented in (Kellogg, 1998).

Cheap solutions that connect the solar panel directly to the battery terminals using a simple rectifier diode to prevent battery discharge on the panel cannot be applied on a large scale or in any situation, so a smart circuit must be used to properly charge the battery.

This paper presents a circuit that can be used as interface between a low-power low voltage solar panel (10...30W, 5...9V) and a lead-acid battery (12V, 45...60Ah, usually used in cars). The presented controller is currently in use in a remote habitat, to assure continuous power source for illumination and radio-reception. Three LED light bulbs (7-10W/LED lamp) and a low power (2W) radio receptor are the only loads that are connected to the battery a few hours everyday. A 20W/6V solar panel generates enough energy for this task, even in partially cloudy days. System has already proven its reliability over one year period of time. The following sections will present the proposed electronic circuit, the associated mathematical equations and some experimental results that prove the excellent operation of the circuit.

2. REQUIREMENTS

The fact that solar panel's output voltage is lower than battery nominal voltage implies that a boost circuit needs to be used to increase the solar panel's voltage to a value usable for battery charging.

After studying the charging rules for lead-acid battery (Clondescu *et al.*, 1977), and other researches, (Wilkinson *et al.*, 1998), (Lam *et al.*, 1995), the following conditions resulted for longest life of the battery:

- battery must be charged with a current lower than 10% of the nominal capacity; charging the battery with short current pulses prolong the life of the battery;
- battery can be stored a very long period of time in the "fully charged" state, keeping the battery voltage at the "float" level (14.4V to 14.7V depending of manufacturer);
- battery should not be overcharged or discharged (could lead to irreversible wear of the battery due to electrolyte evaporation or sulfate crystals forming on electrodes);

According to these requirements an electronic circuit with the following electrical characteristics needs to be designed:

- energy conversion between solar panel and battery is done with a boost DC/DC converter;
- the battery will be charged with a current lower than 4.5A; 6 V x 3,3 A at the solar panel output means a maximum 1.5A charging current at the battery;
- the circuit connects in a single node the battery, load and output of the boost circuit; this assure the flow of the energy from the solar panel right to the load in daylight conditions, saving the battery from unneeded wear;
- the electronic circuit can be left unattended for a undefined time and will withstand usual failures like: imperfect contacts or total disconnection of the battery/ solar panel/ load;
- the circuit will not allow the battery to discharge on the solar panel in no-light conditions; load is disconnected if battery discharges below a minimum threshold.

3. PROPOSED SOLUTION

The main component of the circuit is the DC/DC boost converter. To assure its optimal operation, a microcontroller is used to generate the control signal, taking into consideration three input signals: battery voltage (used as feedback information), solar panel's voltage and current.

The chosen microcontroller is a general purpose, low cost one, but it features a 10 bit analog to digital converter (ADC) module, as well as 10 bit pulse width modulation (PWM) module.

Figure 1 present the block diagram of the circuit:

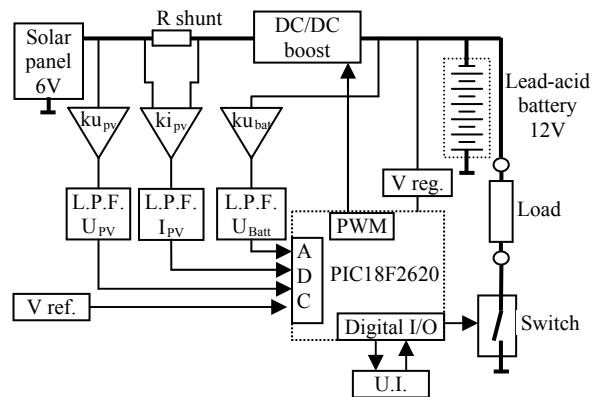

Fig.1. Block diagram of the circuit.

Low pass filters (LPF) are used after current and voltage transducers to prevent high frequency signal components (produced by the DC/DC converter) to reach the inputs of the ADC. A voltage reference is used in association with ADC of to assure precision and stability of the conversion. Load is connected to the battery through a digital switch. User interface (U.I) comprises four LEDs, three momentary switches and an external graphical display (optional).

All the electronics circuits are powered all the time from the battery using a linear voltage regulator. Given the fact that microcontroller and associated components uses low amount of power, the use of a switch-mode power supply is not justified.

4. CIRCUIT OPERATION

This section presents the operation of the previous mentioned blocks, highlighting the important aspects for each module.

4.1. DC/DC boost voltage converter

The voltage converter, presented in Figure 2, uses a classical boost structure (Carl *et al.*,1986), (Christophe, 2008): MOSFET transistor Q1, inductor L1, fast diode D1 and output capacitors (battery will be connected in parallel with the output capacitors).

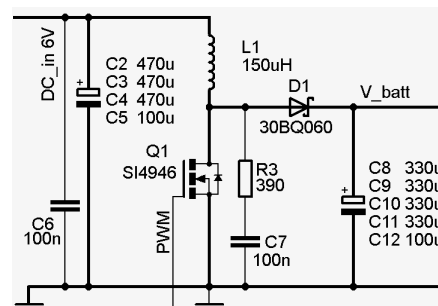

Fig.2. DC/DC voltage converter

The output current is always pulsed, so the battery will be charged with current pulses. According to (Wilkinson, 1998), it is advantageous to charge a lead-acid battery with current pulses.

Diode D1 will prevent the battery to discharge on the solar panel during the night, when PV panel generates a very low voltage and the DC/DC converter does not operate.

The output capacitors are used mainly to lower the rise speed of output voltage if battery is removed.

For this type of converter, there are two major operating points: with continuous current through inductor L1, and with discontinuous current.

In the first situation, the mean value of the output voltage depends on the duty cycle of PWM input signal:

$$(1) U_o = \frac{U_{in}}{1-d}, \text{ where}$$

U_o = output voltage, no load condition,

U_{in} = input voltage,

d = duty cycle of the PWM signal

In the second situation, the input-output relation is more complex:

$$(2) U_o = U_{in} \left(1 + \frac{U_{in} \cdot d^2 \cdot T}{2 \cdot L \cdot I_o} \right), \text{ where}$$

T = period of the PWM signal,

L = inductance of L1

I_o = average output current

In the present application, the battery will be charged with current pulses, no matter if the converter works in interrupt current regime or not. Here, the discontinuous current operation implies only that the input current is pulsed too. Capacitors C2...C5 are used at the DC/DC converter input to deliver these current pulses, improving the solar panel's behavior.

According to equation 1, it is expected that during high illumination of the PV panel, the converter will work at about 60% duty cycle, with continuous current through L1; but in low-light condition controller will produce a PWM signal with lower than 50% duty cycle, so that the discontinuous current will occur.

Inductor L1 was manufactured on an EFD25 gapped ferrite core (EPCOS, 2006). Three windings were connected in parallel, each one consisting of 21 turns of 1mm diameter copper wire. The resulted inductor has very low electric resistance (0.014 Ω) and high

quality factor (5, measured with ESCORT ELC-132A LCR meter, at 1 kHz). The air gap of the ferrite core prevents saturation of the magnetic core for currents higher than 3A.

Because of the high quality factor of L1, the stray capacities in the circuit, and the discontinuous current mode of operation, free oscillations are likely to occur in the Q1's drain during discontinuous current mode. Figure 3a) shows these oscillations (of about 600 kHz) during the entire interval when inductor current is zero. Figure 3b) shows the same signals, but with R3-C3 snubber added.

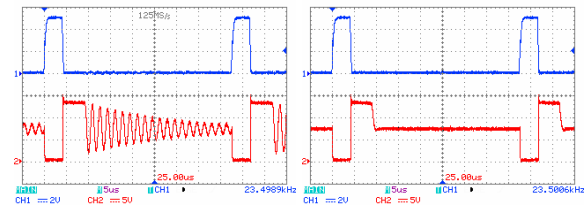

Fig.3. Q1: gate signal (CH1, blue), drain voltage (CH2, red), a) without, b) with snubber.

4.2. The current transducer

To estimate the amount of power that the PV panel can deliver, a current transducer is necessary between PV panel and the DC/DC converter. The shunt resistor is placed between PV panel and smoothing capacitors C2...C5 (from Figure 2). This way the current that passes through the shunt resistor does not contain high frequencies harmonics generated by the DC/DC converter.

Figure 4 presents the electronic circuit used as current transducer:

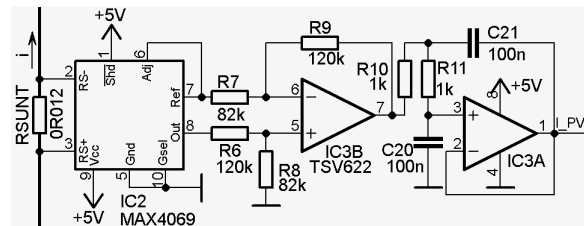

Fig.4. Current transducer

To minimize the power losses on the current sensor, two solutions are possible: use of a Hall current transducer (eg. ACS712 from Allegro Microsystems), or use of an instrumentation amplifier together with a low value shunt resistor. The second solution has been chosen because of the gapped core of the inductor L1, placed close to the current sensor circuitry.

The transducer is build with two integrated circuits: IC2 – a specialized "high side, bipolar current transducer", and IC3 – a dual rail-to-rail operational amplifier, used as IC3B – subtracting amplifier and

IC3A – second order low pass filter. The subtracting amplifier is needed because at the *Out* pin of IC2 we have

$$(3) U_{out} = 50 \cdot U_{Rshunt} + 1.25 \text{ V}$$

After the subtracting amplifier, voltage becomes:

$$(4) U_{P7} = 73.2 \cdot U_{Rshunt}, \text{ where}$$

$$(5) U_{Rshunt} = R_{shunt} \cdot I_{PV}$$

Because the low-pass filter has unity gain for signals in the bandwidth, the output of the current transducer will become:

$$(6) U_{I_PV} = 0.878 \cdot I_{PV}$$

Given the fact that U_{I_PV} must have a maximum measurable value of 4.96V, results the maximum input current that can be sensed:

$$(7) I_{PV_max} = 4.66 \text{ A}$$

Substituting this value in equations (2) and (3) can be observed that neither U_{out} , nor U_{P7} exceeds 5V, so both IC2 and IC3 will operate well within saturation limits.

Figure 5 presents in red the evolution of two signals: a) U_{out} from equation 3, and b) U_{I_PV} from equation 6., as result of changing the duty-cycle from 40% to 45% (blue, CH1, low level means $d = 40\%$, high $d = 45\%$). The switching noise, clearly visible in Figure 5a) is completely rejected from the output signal, Figure 5b).

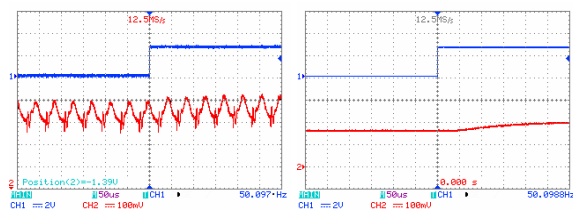

Fig.5. CH1:duty cycle of the PWM (40%/45%), CH2: a) output voltage from the instrumentation amplifier, b) output voltage from the current transducer

4.3. The voltage transducers

Sensing the voltage at the solar panel terminals is done with the transducer presented in Figure 6: a voltage divider followed by a second order low-pass filter, used to eliminate the switching noise. The voltage dividers were added in order to observe the maximum input voltage of the PV panel.

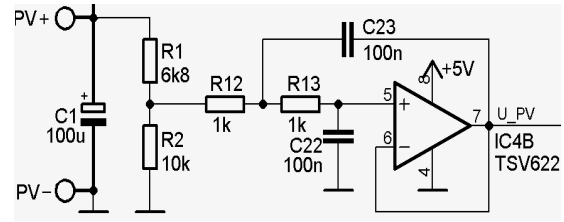

Fig.6. Input voltage transducer

For signals in the bandwidth of the low pass filter, the output is:

$$(8) U_{PV} = 0.59 \cdot V_{PV}, \text{ where}$$

U_{PV} = the output voltage of the transducer,

V_{PV} = the voltage at the solar panel terminals.

For the battery voltage, a filtered voltage divider was used, as seen in Figure 7. The output voltage is:

$$(9) U_{_BATT} = 0.27 \cdot V_{_BATT}, \text{ where}$$

$U_{_BATT}$ = the output of the transducer,

$V_{_BATT}$ = the voltage at the battery terminals.

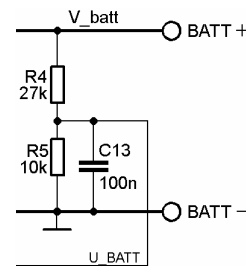

Fig.7. Battery voltage transducer

4.4. Voltage reference

To enhance the stability of the ADC module, a voltage reference needs to be used. Figure 8, present a simple integrated solution:

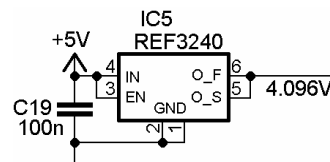

Fig.8. Voltage reference

Given the fact that ADC resolution is 10 bit and maximum analog value that can be converted by the module (with 4.096 V reference) is 4.096 V, results that the input sensibility for ADC module is 4 mV/LSB. This value is suitable both for reading the current and voltages.

4.5. Microcontroller

Figure 9 presents the microcontroller (Microchip, 2004) with associated components: crystal oscillator, in circuit serial programming port, LEDs, momentary switches and display connector. The 5 V power source is obtained with a linear voltage regulator, powered from the 12 battery to assure the continuous operation of the microcontroller and display even when the solar panel does not produce usable energy. The whole electronic circuit uses about 30 mA (even lower is possible if the microcontroller enters in "sleep mode"). User interface consist in 3 push buttons and 4 LEDs or a graphical display. This combination is more than enough even for the development stage of the project.

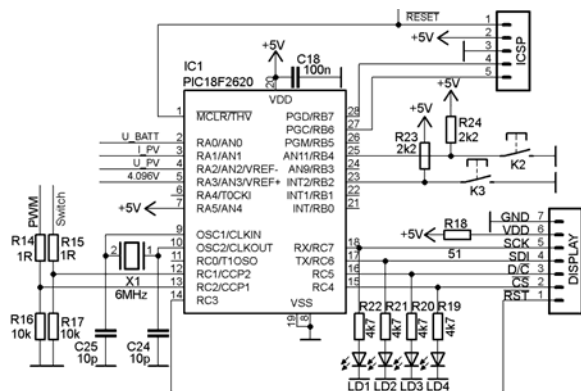

Fig.9. Microcontroller circuit

4.6. Over voltage protection

In the most disadvantageous scenario, the battery can be removed during the time when the DC/DC converter transfer maximum power from the PV panel to the battery. Because the control loop in the microcontroller reads the battery voltage at fixed times, it is possible that the output voltage of the converter to rise to a dangerous level (so that output capacitor explodes, or maximum input voltage for LM7905 is exceeded).

A hardware solution has been chosen: to reset the microcontroller if the voltage at the DC/DC converter rises above a safe value.

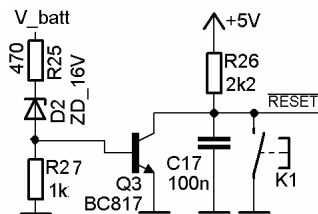

Fig.10. Over-voltage protection circuit

Since the reset input of the microcontroller has the highest priority, the microcontroller will restart right after the protection circuit has triggered the reset signal.

Figure 11 presents the evolution of the DC/DC converter output voltage (blue) and the RESET signal of the microcontroller (red). At $t = 32$ ms, the battery is removed, while PWM duty cycle remain at 60%. In about 25 ms, the output voltage reaches 16V and the RESET line is pulled low. PWM stops instantly and the output voltage falls.

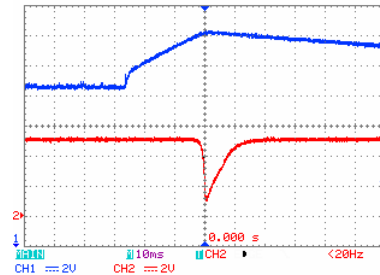

Fig.11. Over-voltage protection circuit

4.7. Load disconnect at low battery

To protect the battery from over discharging, the controller must be able to disconnect any load if battery voltage drops below a specific threshold. Circuit presented on Figure 12 uses a MOSFET transistor to connect the load to the battery. The SI4946 transistor was used because of its low source-drain On resistance (0.05Ω at $U_{gs}=4.5V$), high current capability (6A) and small footprint (SOIC8)

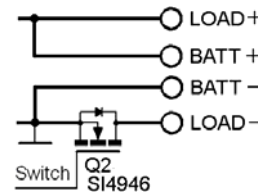

Fig.12. Load disconnect circuit

5. HARDWARE IMPLEMENTATION

The presented electronic circuit was assembled on a 90mm x 55 mm single layer circuit board (PCB). Proper attention has been paid to correct ground routing, because on the same PCB exist paths for high pulsed currents as well as low voltage/high impedance tracks (e.g.: ADC inputs).

Figure 13 presents the routing layer, where the dark blue color was used to highlight the power GND plane, and light blue for small signal GND plane. On the left part of the board are placed the power inductor, switching transistor, filtering capacitors and power connectors for PV panel, battery and load. On the right part of the board, the voltage and current transducers are placed between high power area and the microcontroller.

The two ground planes connect together under the LM7805 voltage regulator.

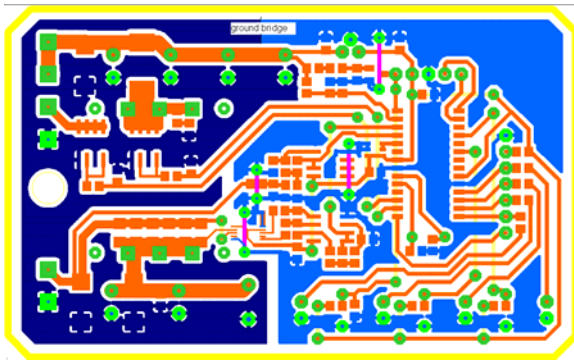

Fig.13. Load disconnect circuit

Figure 14 presents the aspect of the PCB used for tests, Figure 15a) presents the running controller in its case, with the display connected (about 12 W input power under MPPT operation). Figure 15b) shows the solar panel, placed on the house roof.

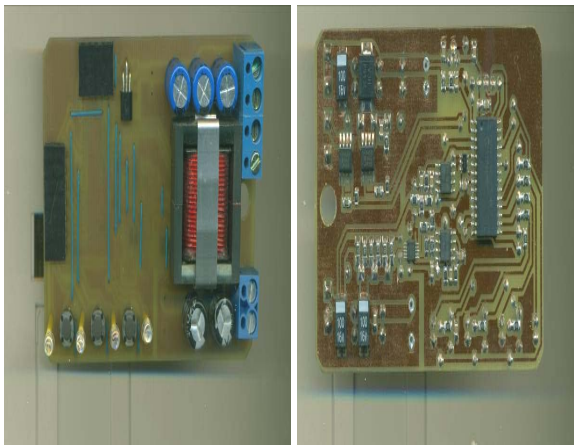

Fig.14. Experimental board, a) top, b) bottom layer



Fig.15. Controller and solar panel under real use.

6. CONCLUSIONS

An electronic circuit was designed and tested to be used as smart battery charger. Energy obtained from a solar panel is passed through a DC/DC boost converter and used to charge the battery with a pulsed current. All the important blocks have been described in detail, both from design and results points of view: DC/DC converter, voltage and current transducers, microcontroller with associated components. The chosen microcontroller allows accurate information readings, as well as proper driving on the DC/DC converter. The presented circuit implements one of the best charging technique for the lead-acid battery, assuring a long service life of the battery. Supplementary protections measures guarantee that battery will not be overcharged or over discharged. By reprogramming the microcontroller used in this circuit it is possible to implement, test and compare the experimental results of various control strategies. A PCB solution for the circuit was presented, highlighting the solution for proper routing on the ground plane.

The circuit is used for more than a year in a real life environment, and is performing well under various weather conditions.

REFERENCES

- Kellogg, W.D.; Nehrir, M.H.; Venkataramanan, G.; Gerez, V.; (1998), *Generation unit sizing and cost analysis for stand-alone wind, photovoltaic, and hybrid wind/PV systems*, IEEE Transactions on Energy Conversion, Mar. 1998.
- Wilkinson J. J. A., Covic G. A., *A new pulse charging methodology for lead acid batteries*, IPENZ Transactions, Vol. 25, No.1/EMCh, 1998
- Lam L.T., Ozgun H., Lim O.V., Hamilton J.A., Vu L.H., Vella D.G., Rand D.A.J., *Pulsed-current charging of lead/acid batteries - a possible means for overcoming premature capacity loss?*, Journal of Power Sources 53 (1995) 215-228
- Clondescu Gh, Tomuta O.D. *Acumuloare electrice - intretinere si reparatii*, Editura Tehnica, Bucuresti 1977
- Carl Nelson, Jim Williams, *Boost Converter Operation, LT1070 Design Manual*, 1986
- Christophe Basso, *Switch Mode Power Supplies: SPICE Simulations and Practical Designs*, New-York: McGraw-Hill. ISBN 0071508589, 2008
- Microchip, PIC18F2525/2620/4525/4620 Data Sheet, <http://www1.microchip.com/downloads/en/DeviceDoc/39626e.pdf>, 2004
- EPCOS - B66421U0315K187 - ferrite core datasheet http://www.epcos.com/inf/80/db/fer_07/efd_25_13_9.pdf, 2006
- Maxim Semiconductor, MAX4069 datasheet: <http://datasheets.maximic.com/en/ds/MAX4069-MAX4072.pdf>, 2008