

BUCK SUPPLIES OUTPUT VOLTAGE RIPPLE REDUCTION USING FUZZY CONTROL

Nicu Bizon

University of Pitesti, Str. Targu din Vale Nr. 1, Pitesti, 110040

Abstract: Using the PWM control for switching power supplies the peaks EMI noise appear at the switching frequency and its harmonics. Using randomize or chaotic PWM control techniques in these systems the power spectrum is spread out in all frequencies band spectral emissions, but with a bigger ripple in the output voltage. The proposed nonlinear feedback control method, which induces chaos, is based by fuzzy rules that minimize the output voltage ripple. The feasibility and effectiveness of this relative simple method is shown by simulation. A comparison with the previous control method is included, too.

Keywords: fuzzy control, anticontrol of chaos; buck converter; power spectrum; output voltage ripple.

1. INTRODUCTION

DC switching power supplies usually name as DC-DC converters are some of the most widely used circuits in electronics systems (Batarseh, 2004; Bizon, 2004). They are usually used to obtain a stabilized output voltage from a given input DC voltage which is lower (Buck) that input voltage, or higher (Boost) or generic (Buck-Boost) (Agrawal, 2001; Rashid, 2003). Most used technique to control switching power supplies is Pulse Width Modulation (PWM) and the desired output voltage ripple is obtained by filtering the output voltage through an appropriate capacitor (Mohan and Undeland, 2002). Because the switching frequency is fixed, the switch-mode power supplies generate electromagnetic interference at the switching frequency and its harmonics. High spectral power peaks produce ElectroMagnetic Interference (EMI) and create significant electromagnetic compatibility difficulties, especially when the DC-DC converter is for high power (Mogel *et al.*, 2005; Ken, 2001; Li and Zhang, 2005); Banerjee *et al.*, 2002). The reduction of power supply EMI can be achieved through various methods that change the switching frequency (Wong *et al.*, 2002; Stankovic *et al.*, 1995; Tse *et al.*, 2003; Kuisma, 2003). All that techniques reduce spectral emissions by spectral power peaks spreading. Intentionally generation of the chaos usually called chaotification or anticontrol of chaos is a powerful technique that in recent years was utilized in

nontraditional applications from different scientific fields. The classical techniques for chaotification of the DC switching power supplies give an exaggerated output voltage ripple or an undesirable spectrum (Morel *et al.*, 2004), so other improved techniques are proposed (Morel *et al.*, 2005; Wang and Chen, 2000; Li *et al.*, 2006), which improves the EMI and eliminates the above mention drawbacks.

2. PROBLEM STATEMENT

Simulink models are used for all components in block diagram. Figure 1 shows the block diagram of a buck converter that uses a PWM voltage control loop. The circuit has two states: when the IGBT switch is closed, the input DC voltage source provides energy to the resistive load R . The input current is filtered by the inductor L . During the interval when the IGBT switch is open, the inductor current flows through the FW diode and transfers some of its stored energy to the load. A continuous current mode (CCM) is considered for buck operating mode.

The basic PWM voltage control loop appear when the manual switch in to ul position and feedback command voltage is:

$$v_{cl}(t) = ul(t) = g_1 \cdot (v_o(t) - V_{ref}) \quad (1)$$

where g_1 is a gain factor.

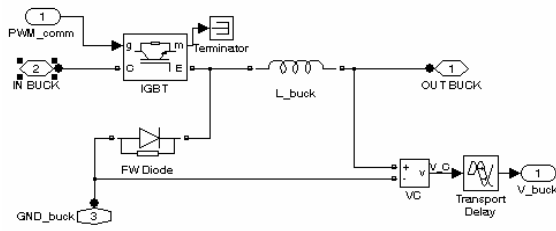

Figure 1.a. Simulink model of a buck converter

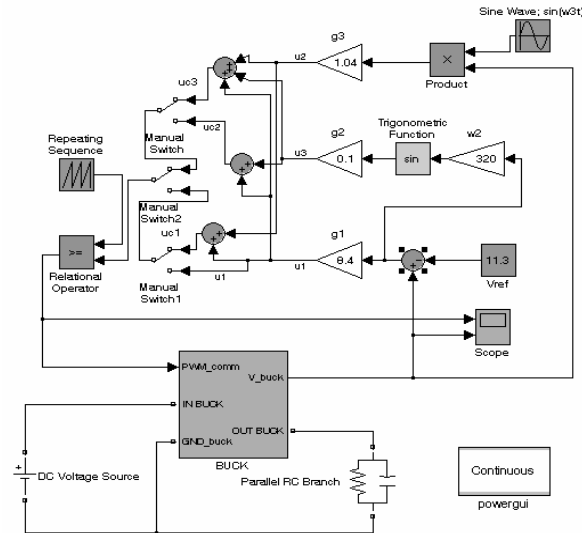

Figure 1.b. The PWM voltage control loop

The $v_{cl}(t)$ voltage is compare with saw-tooth voltage in order to obtain the PWM command. The saw-tooth voltage is defined by relation:

$$v_r(t) = V_L + (V_H - V_L) \cdot \frac{t(\text{mod } T)}{T} \quad (2)$$

and is a decreasing ramp voltage $v_r(t)$ from a higher voltage V_H to an lower voltage V_L in a switching time T . The power spectrum spreading is obtained by system chaotification using a feedback command voltage that is a sum of the previous $u1(t)$ voltage with $u2(t)$ voltage that makes the non-chaotic dynamical system to become chaotic. The control law becomes:

$$v_{c2}(t) = u1(t) + u2(t) \quad (3)$$

The control law $u2(t)$ proposed in (Morel *et al.*, 2004) has the expression:

$$u2(t) = g_2 \cdot \sin(\omega_2 \cdot (v_0(t) - V_{ref})) \quad (4)$$

where the gain factor g_2 and angular frequency ω_2 are chosen as bifurcation parameters.

The output voltage ripple is reduced using a nonlinear feedback command voltage $u2(t)$ that is a added to the previous ones. The control law becomes:

$$v_{c3}(t) = u1(t) + u2(t) + u3(t) \quad (5)$$

The control law $u3(t)$ proposed in (Morel *et al.*, 2005) has the expression:

$$u3(t) = g_3 \cdot v_0(t) \cdot \sin(\omega_3 t) \quad (6)$$

3. PROPOSED FUZZY CONTROL LAW

The control law $uf4(t)$ proposed in this paper in order to minimize the output voltage ripple is generate by a fuzzy controller (FC) which have a nonlinear in-out characteristic (figure 2).

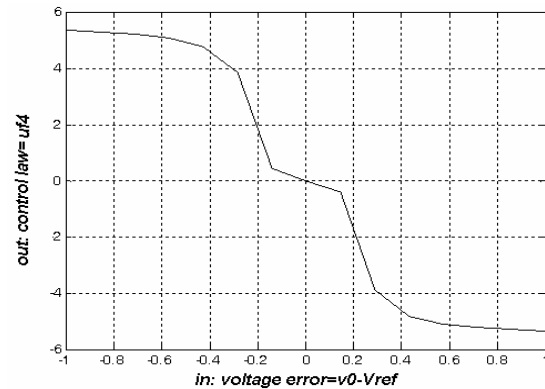

Figure 2. Nonlinear characteristic of the FC

The Matlab program that generates this nonlinear characteristic is:

```
p=10e-3; q=100e-3; v=200e-3; r=1000e-3;a=0.1;
b=0.2; c=1; s=1; d=10;
fisah=newfis('control-ah');
fisah=addvar(fisah,'input','voltage error',[-s s]);
fisah=addvar(fisah,'output','control law',[-d d]);
fisah=addmf(fisah,'input',1,'BBN','trapmf',[-s-s-r-v]);
fisah=addmf(fisah,'input',1,'BN','trapmf',[-r -v -v -p]);
fisah=addmf(fisah,'input',1,'N','trapmf',[-p -p -p 0]);
fisah=addmf(fisah,'input',1,'ZE','trapmf',[-p 0 0 p]);
fisah=addmf(fisah,'input',1,'P','trapmf',[0 p p r]);
fisah=addmf(fisah,'input',1,'BP','trapmf',[p q r]);
fisah=addmf(fisah,'input',1,'BBP','trapmf',[v r s]);
fisah=addmf(fisah,'output',1,'VVS','trapmf',[-d-d-c-b]);
fisah=addmf(fisah,'output',1,'VS','trapmf',[-c-b-b-a]);
fisah=addmf(fisah,'output',1,'S','trapmf',[-b-a-a 0]);
fisah=addmf(fisah,'output',1,'Z','trapmf',[-a 0 0 a]);
fisah=addmf(fisah,'output',1,'B','trapmf',[0 a a b]);
fisah=addmf(fisah,'output',1,'VB','trapmf',[a b b c]);
fisah=addmf(fisah,'output',1,'VVB','trapmf',[b c d d]);
ruleListah=[1 7 1 1;2 6 1 1;3 5 1 1;4 4 1 1;5 3 1 1; 6
2 1 1; 7 1 1 1];
fisah=addrule(fisah,ruleListah);
gensurf(fisah)
```

The main idea is to have a small loop gain if the output voltage ripple is small, too, and, if the output voltage ripple increase, the loop gain rise quickly to a value that assure the stability of the overall feedback loop (Bizon and Raducu, (1998).

The control law $uf4(t)$ is gain with g_4 , so the proposed control law becomes:

$$v_{c4}(t) = u1(t) + u2(t) + u4(t) \quad (7)$$

where $u4(t) = g_4 \cdot uf4(t)$ and error voltage $(v_o(t) - V_{ref})$ is limited to $[-1, 1]$ range, which is the input range of the fuzzy controller.

In order to compare the level of the spectral peaks and the output voltage ripple the same control and circuit parameter and the same system chaotification technique is used in this paper, too (figure 3).

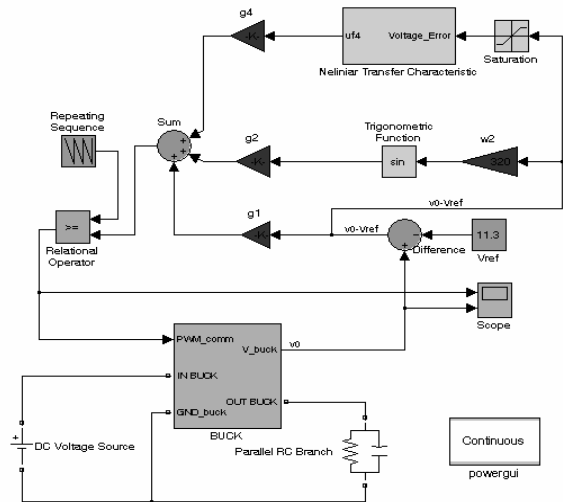

Figure 3. Proposed PWM voltage control loop

4. SIMULATION RESULTS

The values of the fixed parameters are taken from [14,15]: $L = 20\text{mH}$, $C = 47\mu\text{F}$, $R = 22\Omega$, $g_1 = 8.4$, $V_{ref} = 11.3\text{V}$, $V_L = 3.8\text{V}$, $V_H = 8.2\text{V}$, $T = 400\mu\text{s}$, $g_2 = 0.1$, $\omega_2 = 320\text{ rad/V}$, $g_3 = 1.04$, $\omega_3 = 250\,000\text{ rad/s}$, and DC Voltage Source is $E = 16\text{V}$.

The appropriation of the nonlinear controller (that generate $u3$ signal – figure 4, and $u4$ signal figure 5, respectively) determines a chaotic behavior of the buck converter.

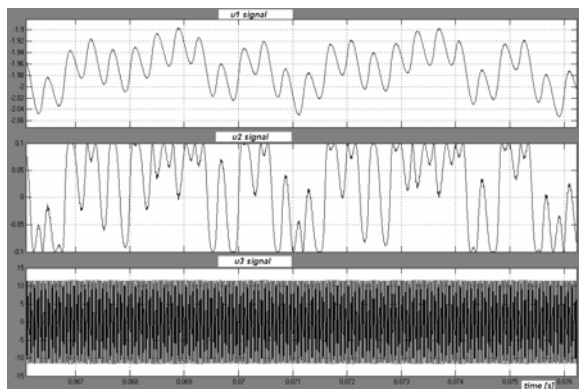

Figure 4. The chaotic behavior of the buck converter shown in figure 1

The output voltage and associate spectrum are represented in figure 6, and figure 7, respectively. A zoom is shown in the bottom of figures 6 and 7, respectively.

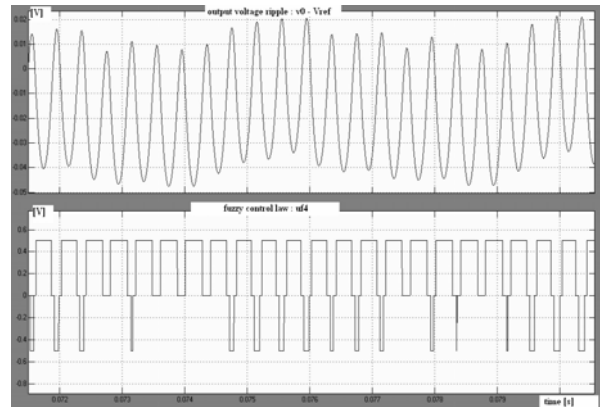

Figure 5. The chaotic behavior of the buck converter shown in figure 4

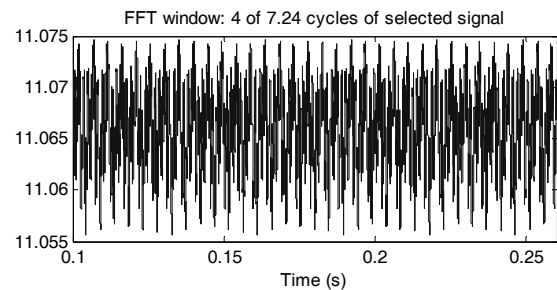

Figure 6.a. Output voltage for control law v_{c3}

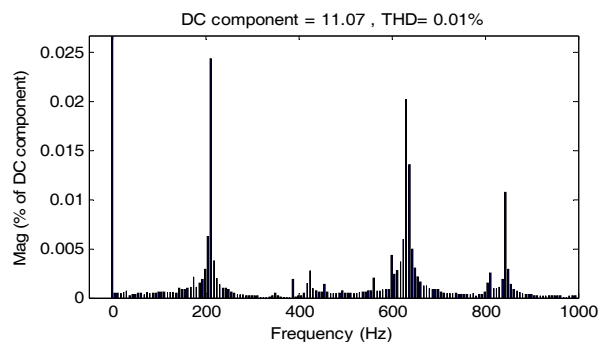
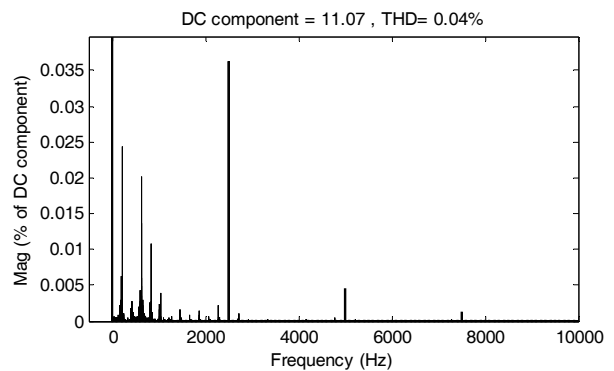

Figure 6.b. Output voltage spectrum for v_{c3}

For other operating condition of the buck converter shown in figure 1, the simulation results are presented in:

- figure 8: only basic control law u_1 ;
- figure 9: adding the control law u_2 (that give low peak of the output voltage spectrum) to u_1 ;
- figure 10: adding the control law u_3 (that give low output voltage ripple) to u_1 .

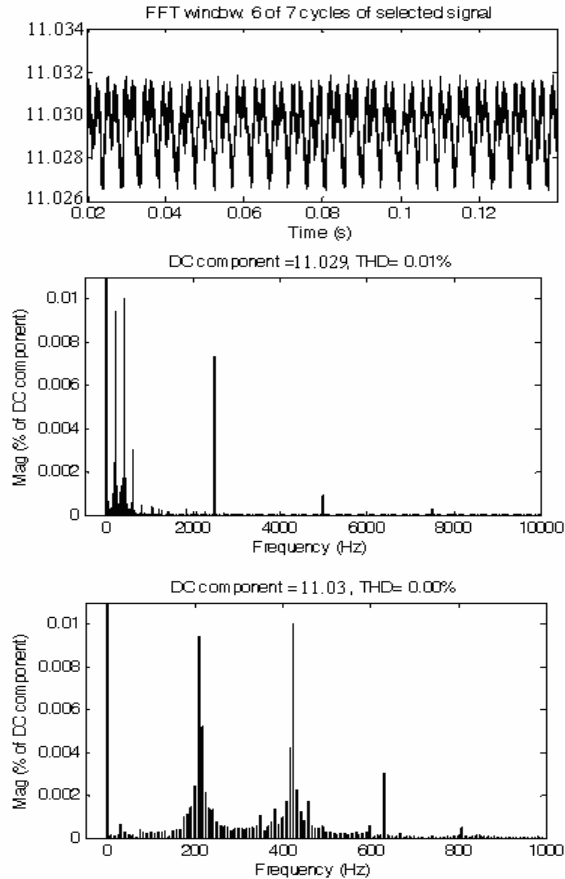

Figure 7. Output voltage and associate spectrum for control law v_{c4}

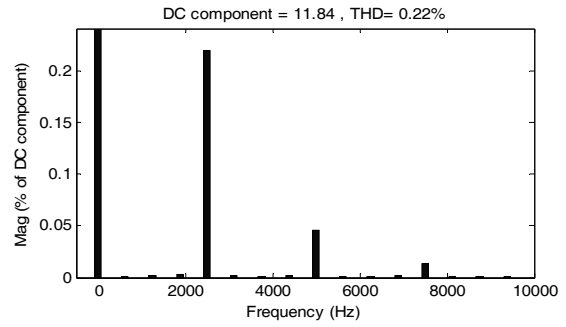
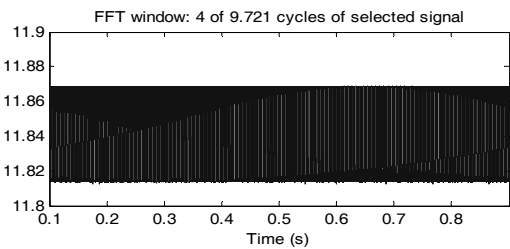

Figure 8. Output voltage and associate spectrum for control law $v_{c1}=u_1$

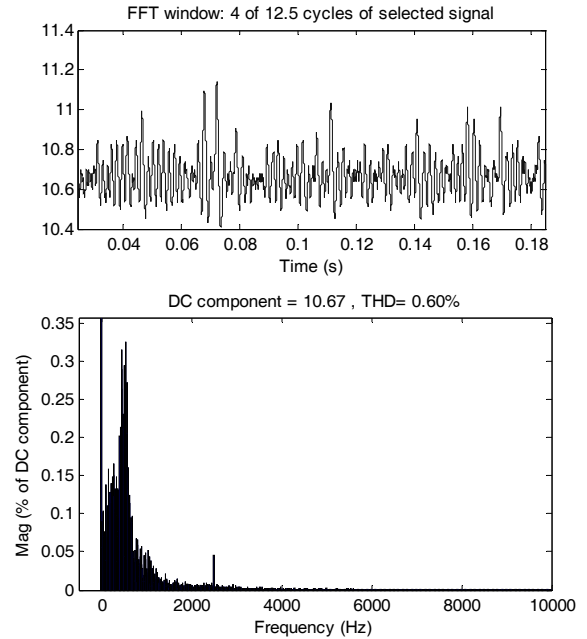

Figure 9. Output voltage and associate spectrum for control law $v_{c2}=u_1+u_2$

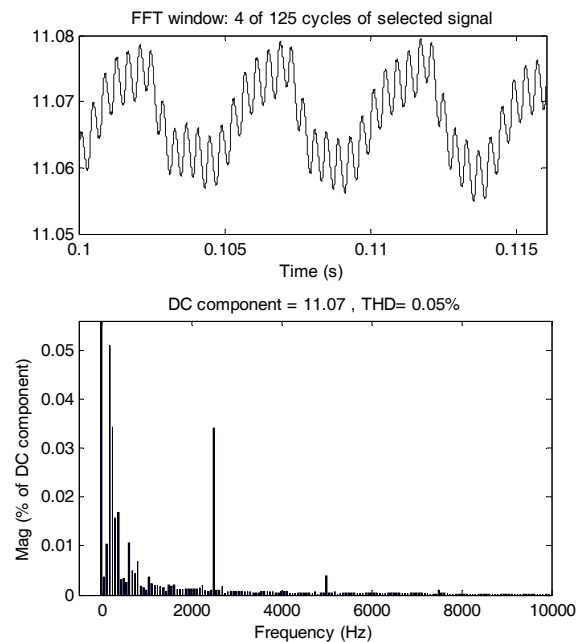

Figure 10. Output voltage and associate spectrum for control law $v_{c5}=u1+u3$

Table 1. The converter performances using different control laws (*vc1*, *vc2*, *vc3*, *vc4*, *vc5*).

Control law	Peak of the v_o spectrum at 2500Hz [% of DC component]	v_o ripple [mV]	Chaos	Wide band
<i>vc1</i>	0.22	60	No	No
<i>vc2</i>	0.03	200	Yes	Yes
<i>vc3</i>	0.035	20	Yes	Yes
<i>vc4</i>	0.007	6	Yes	Yes
<i>vc5</i>	0.035	20	No	Yes

Table 1 summarizes the output voltage ripple and the peak of the output voltage spectrum, using the five control laws (*vc1*, *vc2*, *vc3*, *vc4*, *vc5*) as feedback signals. Furthermore, the output voltage $v_o(t)$ is not sensitive to the variation of the initial conditions.

5. CONCLUSION

The proposed nonlinear controller (designed by a fuzzy controller) maintains a small ripple of the output voltage and combined with a control technique that chaotifying the buck converter operation the new control loop is able at the same time to achieve very low spectral emission and low output voltage ripple. The parameters of this controller are chosen in order to obtain the great performances by trial and error method. There are relatively closely to the reported value in [15]. Because more complex models are used for the electronic components the simulation results are a little bite different to reported value in [15]. The promising results make us to currently work at the experimental setup.

Acknowledgments

The CEEEX Grant #226, CEEEX Grant #310, and CNCISIS Grant #570 of the National Research Council (MEC) have supported part of the research for this paper.

REFERENCES

Agrawal, J. P., (2001) Power electronic systems: theory and design, *Upper Saddle River*, N.J.: Prentice Hall.

Banerjee, S., Kastha, D., Gupta, S., (2002) Minimising EMI problems with chaos, *Proceedings of the International Conference on Electromagnetic Interference and Compatibility*, pp. 162-167, *Kharagpur*, India,

Batarseh, I, (2004), *Power electronic circuits*, *Hoboken*, NJ: John Wiley.

Bizon, N., Raducu, R., (1998) Fuzzy Gain Control for the Control Action of Time Delay Process,

Systems Structure and Control (SSC'98), ed. Elsevier Science, London, UK., pp. 675-680,

Bizon, N., (2004) Power converters (in Romanian language), *Ed. MatrixROM*, Bucharest.

Ken, Y., (2001) Spread-Spectrum DC-DC Converter Combats EMI, *Electronic Design*, pp. 86-88.

Kuisma, M., (2003) Variable frequency switching in power supplies EMI-control: an overview, *Aerospace and Electronic Systems Magazine*, IEEE Vol. 18, Issue 12, pp. 18 – 22.

Li, H., and Zhang, B., (2005) Simulation and Experimental Research on Chaotic DC-DC Boost Converters, *Proc. 16th China Power Supply Society Conf.*, pp. 605 – 609, China, 2005.

Li, Z-Z., Qiu, S-S., Chen, Y-F., (2006) Experimental Study on the Suppressing Emi Level of DC-DC Converter with Chaotic Map, *Proceedings of the Chinese society for electrical engineering*, Vol.26 No.5, pp. 76-81, 2006.

Mogel, A., Krupar, J., Schwarz, W., (2005) EMI performance of spread spectrum clock signals with respect to the IF bandwidth of the EMC standard, *Proceedings of the 2005 European Conference on Circuit Theory and Design*, Vol. , pp. I/169- I/172.

Mohan, N., Undeland, T. M., (2002) Robbins, W. P., *Power Electronics: Converters, Applications, and Design*, *3rd Bk&Cdr edition*, Wiley.

Morel, C., Bourcerie M., and Blondeau, F. C., C. Morel, M. Bourcerie and F. Chapeau-Blondeau, (2004) Extension of chaos anticontrol applied to the improvement of switch-mode power supply electromagnetic compatibility, *Proc. IEEE Int. Symp. Industrial Electronics ISIE'04*, Ajaccio, France,, pp. 447–452.

Morel, C., Bourcerie M., and Blondeau, F. C., (2005) Improvement of power supply electromagnetic compatibility by extension of chaos anticontrol, *Journal of Circuits, Systems, and Computers*, Vol. 14, No. 4, pp. 757–770.

Rashid, M. H., (2003) *Power Electronics: Circuits, Devices and Applications (3rd Edition)*, Prentice Hall.

Stankovic, A.M., Verghese, G.C., Perreault, D.J., (1995) Analysis and synthesis of randomized modulation schemes for power converters, *IEEE Trans. on Power Electronics*, 10(6):680-693.

Tse, K.K., Ng, R.W.M., Chung, H.S.H., *et al.*, (2003) An evaluation of the spectral characteristics of switching converters with chaotic carrier-frequency modulation, *IEEE Trans. on Industrial Electronics*, Vol. 50(1), pp. 171-182.

Wang, X. F., Chen, G., (2000) Chaotifying a stable map via smooth small-amplitude high-frequency feedback control, *Int. J. Circuit Theor. Appl.*, no. 28, pp. 305–312.

Wong, H., Chan, Y., Ma, S.W., (2002) Electromagnetic interference of switching mode power regulator with chaotic frequency modulation, *23rd Int. Conf. on Microelectronics - MIEL 2002*, Vol. 2, pp. 577 – 580.