

PARAMETRIC MODELLING OF PILOT STATION FOR PRODUCTION OF VEGETAL BIOSTIMULANTS

Lecturer Diana ANGHELACHE Ph.D
Assoc. Professor Ioana DIACONESCU Ph.D
"Dunărea de Jos" University of Galați,
Faculty of Engineering and Agronomy
Braila, Romania
Research Center for Mechanics of Machines
and Technological Equipments

ABSTRACT

The purpose of this paper is to explain the need for a pilot station of a biodegradation platform and the process of modeling it. Such platform is intended to produce vegetal bio-stimulants to protect tomatoes, vegetable marrows, lettuce, corn, wheat, oats and other crops. The bio-stimulants are obtained from residual organic waste such as leaves, stems and branches. Modeling of the entire assembly for pilot station was achieved in Autocad 2015.

KEYWORDS: pilot station, bio-stimulants, modelling, process flow, medicinal herbs, organic waste.

1. INTRODUCTION

Organic farming is a dynamic sector in Romania which has seen in recent years an upward trend in the vegetable sector.

The agricultural waste is the most accessible and cheap source of organic matter, chemical composition having all the nutrients that plants need for growth and balanced development. By chopping and incorporation of plant residues in the soil, physic-chemical indices of soil fertility can be improved.

Therefore, the necessity of some bio-fertilizers and bio-stimulants for plants is in continuous growth, in conjunction with the use of renewable resources and with Regulation (EC) No. 2003/2003 of the European Parliament and of the Council of 13 October 2003 relate to fertilizers, with subsequent additions. This paper presents a partial result of a research study developed into BIOSTIM project.

By implementing this stage of work all legal regulations on the production of plant

growth stimulators will be considered.

Also, it will be considered their use for sustainable organic agriculture and horticulture to enhance quality of agricultural and horticultural products.

2. PRELIMINARY SOLUTION FOR BIODEGRADATION PLATFORM – PILOT STATION

One of the goals of this paper is to conceive and design a process flow for obtaining of vegetal bio-stimulants.

The designed biodegradation platform is intended to produce vegetal bio-stimulants starting from organic waste, resulted after harvesting of agricultural and horticultural crops, mixed with bio-fungicide, as medicinal herbs extract, mixture that ensure the mineral elements and increase of resistance to diseases for various cultures.

The technological process to produce bio-stimulants is sequenced as follows:

- Landfill supply with organic waste (bio-mass), mainly as straw and leaves;
- Chopping of organic waste to suitable dimensions;
- Compost (chopping) conveyance into a mixing basin;
- Mixing the chopping with hot water and air, thus resulting a compost with high humidity;
- Making even and biodegradation of humidified compost by stirring for one week;
- Filling the basin with water, the result being the final compost, that is periodically stirred for homogenization and biodegradation purpose, for one more week;
- Compost outlet and its pressing;
- Separation by pressing of the liquid part (bio-fertilizer) from solid part;
- The bio-fertilizer is collected in an outlet basin where it is mixed up with medicinal herbs extract this way resulting the vegetal bio-stimulant;
- The vegetal bio-stimulant is pumped to a bottling station in plastic recipients;
- The solid part of the compost is out flown on a conveyor belt, being used as solid substrate for vegetation boxes and aqua-ponic crops or it is bagged and delivered to greenhouses as solid organic substrate.

2. 1. Equipment used to realize the pilot station for obtaining bio-stimulants

In this section the equipment needed for the process of obtaining vegetal bio-stimulants will be set (Figure 1), thereafter their location and dimension being done within engineering stage for biodegradation platform.

Pilot station will be located in an industrial hall with a 140 m² surface area and will have a raw material (bio-mass) landfill attached with an available area of 50 m², and maximum storage capacity abt. 75 m³.

Power supply will be provided by a transformer substation located next to industrial hall [1].

Water supply will be provided by means of a buffer tank that will be dimensioned based on pilot station peak consumption.

Compressed air system will consist of one ring laid down on inside periphery of industrial hall and be supplied by one compressor.

The landfill is crossed by a conveyor belt (1), electrically driven, having 1m width, equipped with one feeder at the end where the vegetal waste chopper (2) is located [5].

Belt conveyors can be used as horizontal convey or on inclined direction to an angle among 5-25⁰ from horizontal, both for bulk loads and loads in pieces.

The chopper is of rotating drum type with six knives on generating line and one counter-knife fixed on the housing. The rotating drum of the chopper is equipped with flaps for pneumatic conveyance of the chopped material and it is driven by an electric motor. The resulted chopped material will have the size among 15-20 mm.

The chopped material will be out flown by the chopper into the de-dusting cyclone (4) its air vent passing through the hall ceiling to the outside to remove the dust resulted from chopping process.

The cyclone is centrally located above the mix basin (3), and the compost will fall down, through the lower outlet connection of the cyclone, into the mixing tank.

The mix basin can be placed on a concrete foundation of 0.6 m height, ensuring the needed level drop for a good progress of the final compost pressing process [1].

In the basin, the compost will be mixed with hot water, respectively cold water, in the two distinct stages of the technological process.

The inside surface of the basin will be covered, as mentioned in previous paragraph, by hydro-insulating foil to avoid changing of chemical composition and physical properties of the compost further to direct contact with concrete walls of the tank, during the two weeks. During the two stages the compost will be periodically mixed by the horizontal/vertical stirrer (5), for the purpose of homogenizing and biodegradation.

The stirrer is intended for transmission of mechanical power from the dynamic elements of the equipment to the mixed media (humidified compost).

The stirrer type is selected first of all based on the intended technological process.

This is a complex operation considering the multiple problems that come up in obtaining an optimum flow range and ensuring a reduced time for mixing. In current situation, mixing should be periodically done on horizontal direction simultaneously with vertical direction.

This way, the selected solution will be an electrically driven stirrer that travels on horizontal direction on some guides that are installed on the edge of the basin, and blades with suitable geometry will be installed on stirrer's shaft, ensuring vertical mixing of the compost by rotation around the shaft.

Also, compost homogenizing on horizontal direction is ensured by shaft travel on the side guides.

After two-staged biodegradation process ends, the compost is guided to a hydraulic press (7) and out-flown by means of a blade scraper (6).

Due to geometry of the blade scraper, determined based on the basin dimensions and final quantity of compost, the compost gathers around the outlet valve having a constant flow rate.

Outlet valve will be a valve with blade, with increased section to ensure high consistency compost outlet with constant rate.

By controlled drive of the scraper blade the outlet flow is kept at desired values.

For the case when high consistency compost flows come up in the outlet valve, the tank will be provided with a helical extractor (12) at the outlet, ensuring continuous feed of the press.

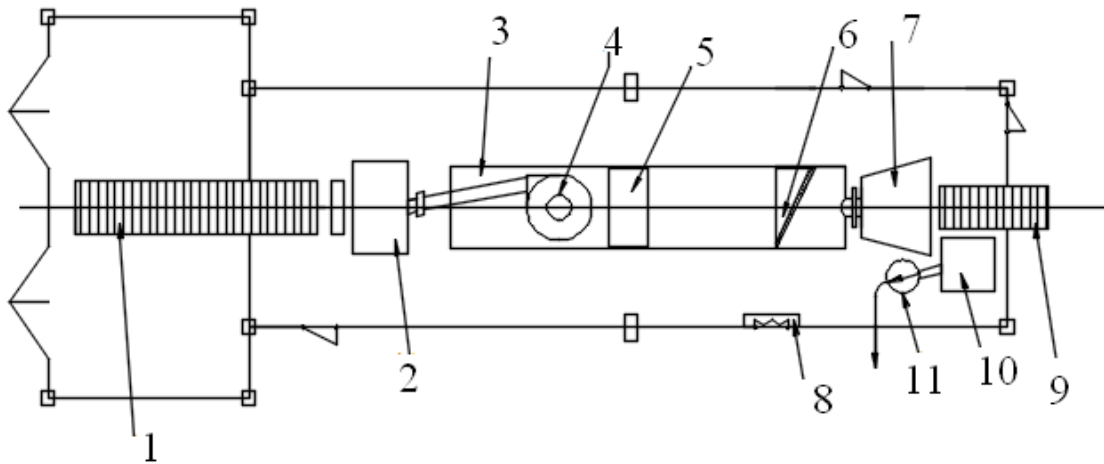

Fig. 4 Preliminary flow diagram of the pilot station

- 1 - bio-mass conveyor belt, 2 - drum type straw chopper, 3 - mix basin, 4 - de-dusting cyclone, 5 - worm stirrer, 6 - blade scraper, 7 - hydraulic press, 8 - hot water boiler, 9 - conveyor belt for solid compost from press, 10 - final product tank, 11 - pump

The liquid part resulted after pressing is a bio-fertilizing substance and is collected in a final product tank (10) where it is mixed with medicinal herbs extract. After mixing, the result is the final product, meaning the liquid bio-fertilizer that is conveyed by pumping (11) to the station for bottling into plastic recipients. Resulted recipients are labeled and sent for sale.

The solid part will have a maximum final humidity of 20% and be removed through a conveyor belt (9) to a concrete platform located in front of the basin, following to be delivered as solid substrate for vegetation boxes and aqua-ponic crops or be bagged and sold as solid organic substrate. Compost outlet stage can operate in intermittent mode, so that the final compost will be pressed in lots, and the biofertilizer obtained per each pressing lot will be mixed with different quantities of medicinal herbs extracts, this way obtaining bio-stimulants of various concentrations, depending on consumers' demand.

The first stage of the process needs hot

water, which will be supplied by a hot water boiler (8), located inside the pilot station in the wet part area of the process to avoid existing risk of fire as the enclosure is filled with easily flammable dust, in the area of the chopper and de-dusting cyclone.

An electric boiler can also be considered, as this is a more safe solution regarding fire-fighting because there is no open flame, to provide the hot water needed for the process and consumption, but the disadvantage is that hall heating cannot be ensured during the cold period of the year.

The final compost is out-flown into a hydraulic press (7), its function being to separate the solid part from the liquid part. In principle, the press will consist of one recipient and one mobile element, which during separation process lower the pressing volume. The pressing recipient has strong and perforated walls, so the liquid is let to pass through.

After introducing the final compost to be pressed, at the beginning the liquid flow happens without acting from exterior, but only

by material layer pressure effect.

This first stage is a pure filtering process under influence of a liquid column.

3. PRELIMINARY TECHNOLOGICAL SOLUTION – PILOT STATION

The previously identified preliminary

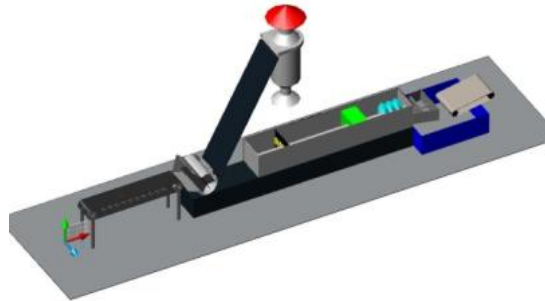
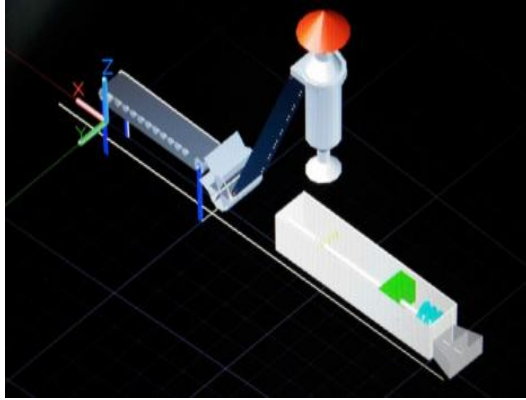

Fig. 2- 3D modelling stages for pilot station

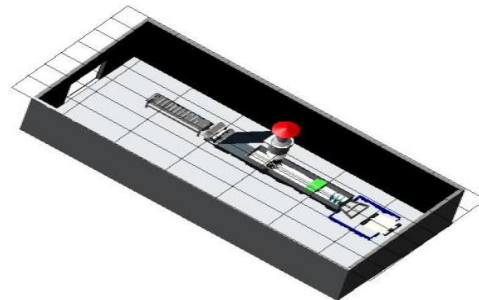
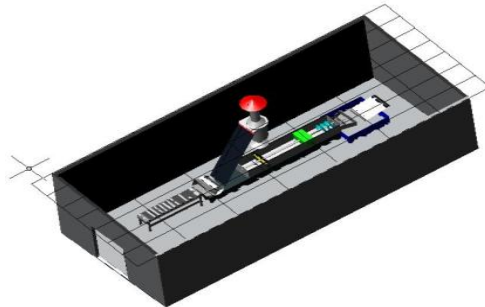

Fig. 3- 3D modeling stages for biodegradation platform

4. CONCLUSIONS

Vegetal waste is the most accessible and cheapest source of organic matter, its chemical composition including all nutritive elements needed by the plants for a balanced growth and development. By chopping the vegetal waste and their inclusion in the soil, the physical-chemical factors of the soil fertility can be improved.

This paper aims to find a technological solution for obtaining vegetal bio-stimulants to be put into practice within the future stages of the BIOSTIM project by designing and construction of a vegetal biodegradation platform having as final product: obtaining of vegetal bio-stimulants.

This paper is the result of a first stage of the project, wherein, by applying a parametric modeling on the basis of technological process for bio-stimulants production, the technological

solution can be presented as 3D representations, developed with a specialized soft and shown in figures 2 and 3[2], [3], [4].

solution is identified and a preliminary diagram of the pilot station is proposed.

REFERENCES

- [1] Alămoreanu Mircea, Coman Liviu, Nicolescu Șerban - „Lifting Machinery”, Vol. 1, Vol. 2, Technical Publishing House, Bucharest, 1996, ISBN 973-31-0827-8, ISBN 073-91-0920-
- [2] Goanță A. M., Bordei M. – „Computer Aided Engineering”, ISBN 973-700-070-6, Aius Publishing House, Craiova 2005.
- [3] Goanță A. M. – “Infographics 2D/3D”, ISBN(13) 978-973-9458-81-8, LUX LIBRIS Publishing House, Brașov, 2006
- [4] Lihtetchi I., Ivan M-C., ș.a., „ 3D Aided Graphics in AutoCAD”, Publishing House of Transylvania University in Brașov, 200
- [5] Oproescu Gheorghe - „Machinery and systems for Industrial conveyance”, Edmunt Publishing House, 2001, Brăila, ISBN 973 98906-9-5.