

# ADVANCED GEOMETRICAL TOOLS FOR MODELLING PLASTIC MEDICAL ACCESSORIES FOR THE AEROSOL INSTRUMENTS DEVICES

PhD. Assoc. Prof. Adrian Mihai GOANTA  
"Dunarea de Jos" University of Galati -  
Romania, Faculty of Engineering in Braila,  
Research Centre for Mechanics of the  
Machines and Technological Equipments

## ABSTRACT

*This paper aims to present some advanced modelling tools used in modelling three-dimensional plastic medical accessories related to aerosol devices. The tools presented in the paper are applied in particular to generate specific geometries obtained by injecting plastics. Basically these instruments have been studied and analyzed to generate the geometrical model of a mouth mask of an aerosol device.*

KEYWORDS: CAD, parameterized modeling, SIEMENS NX

## 1. INTRODUCTION – AEROSOL DEVICES

Aerosols are present on the sea and ocean cliffs, in the salt specially designed or can be created by means of aerosol devices. Salt aerosols have the same beneficial properties on the body clearing the airways from outbreaks of infection such as staph present mostly in children.

Saline aerosol is formed by combining the salt with air resulting in an environment rich in sodium chloride. When one can not or does not have time to follow a proper treatment in salts or at sea, one can resort anytime to home aerosol devices. These devices use substances to create aerosols identical to those present in nature and have the great advantage that can be used at home. In case of asthma, aerosols smooth the bronchospasm tendency, clear and unplug bronchial secretions, reduce inflammation and increase the amplitude of respiration. By performing deep breathing, aerosols dilate blood vessels and thus the whole body is better oxygenated and brain processes are accelerated.

Currently there are three major classes of devices that generate aerosols: nebulizers,

pressurized inhalation dosing devices, dry powder inhalation devices. Nebuliser is a device that turns a drug solution into fine aerosol particles with sizes ranging from 1.5  $\mu\text{m}$  to penetrate the lower breathing airways so as to produce an optimal effect. There are three types of nebulizers used by patients: with compressor (airflow), ultrasonic and vibrating metal mesh. The aerosol method generated by nebulization is a modern and effective medication management with obvious results, which have revolutionized the treatment of respiratory diseases such as asthma and obstructive pulmonary brooch (chronic bronchitis and emphysema). Both global competitive pressures and rapidly growing demand for efficient, cheap and fast nebulizer systems together with technological progress in nanotechnology and microelectronics have led to fundamental changes in the nebulization processes and technologies.

## 2. COMPOSITION OF COMPRESSING DEVICES

All these types of devices are characterized by a bulky box containing the air compressor. For better mobility this is provided with a storage compartment for all accessories that

come with it. Whatever constructive and functional solution for these devices, absolutely all of them are equipped with air filtration system that can vary from one model to another. Components of the studied device are shown in Figure 1 and the caption below.

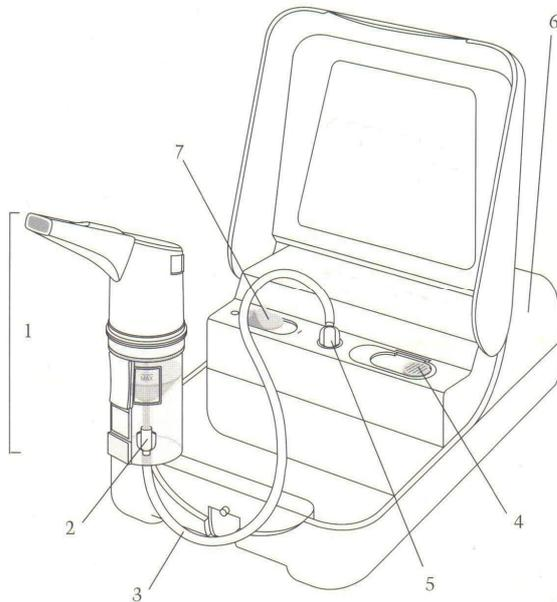

Fig. 1. Aerosol device components

The components of the aerosols device are: 1 - nebulisers Kit, 2 - Air Inlet connection to the nebulisers kit, 3 - Air tube with 2 connectors, 4 - Filter compartment, 5 - Air outlet connection from the main unit, 6 - Main unit, 7 - OFF / ON switch. Figure 2 shows the axonometric representation of the nebuliser Explosional 3D modeled in this paper. A nebulizer accessories are: 1 - Mouthpiece with exhalation valve, 2 - Inspiratory valve, 3 - Nebulisers head, 4 - Vaporized head, 5 - Air guide, 6 - Scaling ring, 7 - Medication tank, 8 - Control switches, 9 - Jet nozzle.

### 3. ADVANCED TOOLS FOR MODELLING PLASTIC ACCESSORIES OF AEROSOLS EQUIPMENT

This chapter further presents those advanced modelling controls of Siemens NX software that lead to the particular geometric shape of the mouth mask accessory of an aerosol device. Out of all the controls that appear in "Part Navigator" related to the accessory being studied, we will present only the dialog boxes related to controls Through Curve, "Trim Body", "Shell", "Swept", "Sew" and "Patch". "Through Curves" control is equivalent to the well known control from other design media - "Loft" and enables to generate a solid by connecting two or more

sections that can be found along a connection path. Dialogue sections of this control are: "Select Curve", "Continuity", "Alignment", "Surface Output Options", "Settings", and "Preview". Their dialogue and application to generate mouth connector are shown in Figure 3.

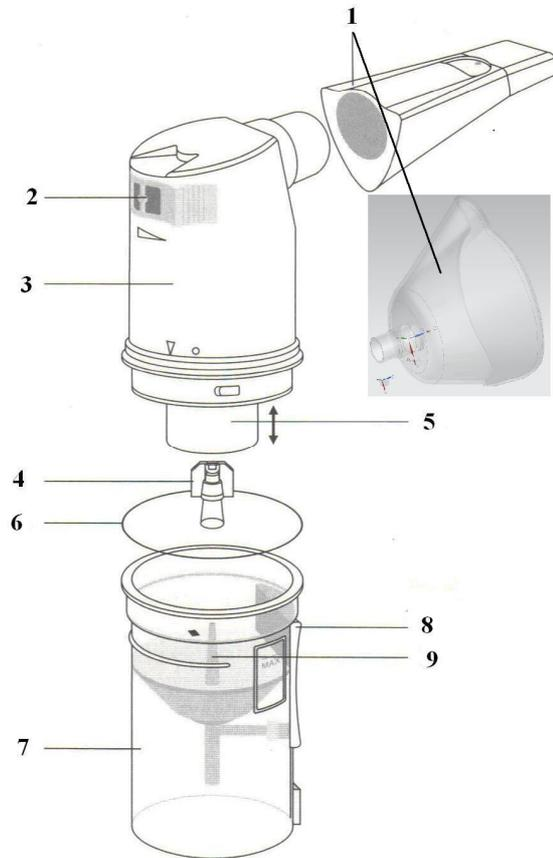

Fig. 2. Nebulizer components

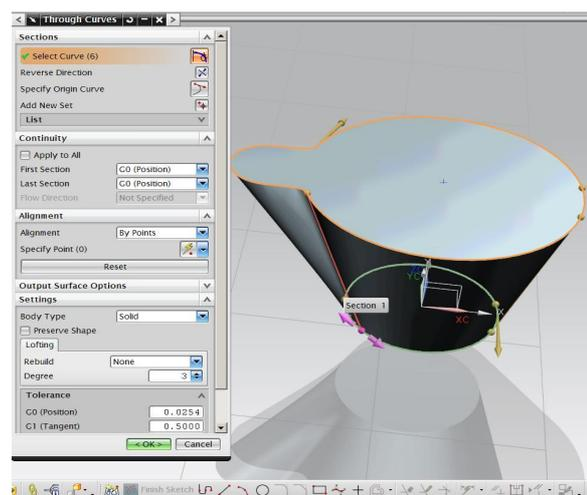

Fig. 3 "Through Curve" window

It should be noted that the way of selecting the curves under this control is essential for its successful implementation which is why it is recommended that the two points indicated for

the curves selection should be on the same side of the future body being generated. Also, after selection of the first curve, press the "Add New Set" to allow selection of the second curve.

The "Trim Body" control implies to define in an earlier stage a surface generated by one of the specific methods that will be applied as cutting surface to the 3D solid body up to that moment. Basically the user has the possibility that after selection of the two entities to indicate what portion of the solid should be cut off. The dialogue window and the application mode are presented in Figure 4.

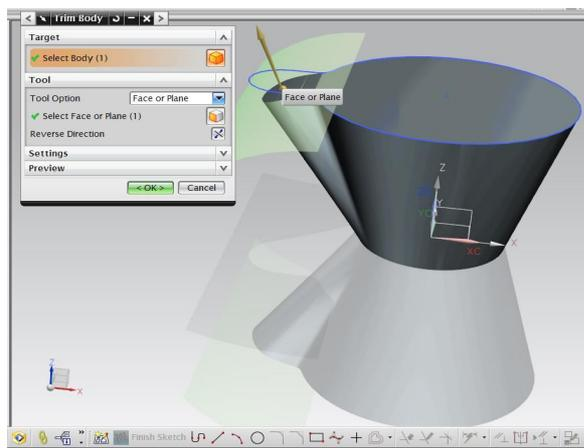

Fig. 4 "Trim Body" window

A second 3 D modelling tool used to generate solids associated with the nebulizer accessories is the control "shell". This has the following dialogue sections: Type, Face to Pierce, Thickness, Thickness Alternate, Settings, and Preview. All these sections and how to apply them on the nebulizer body are presented in Figure 5.

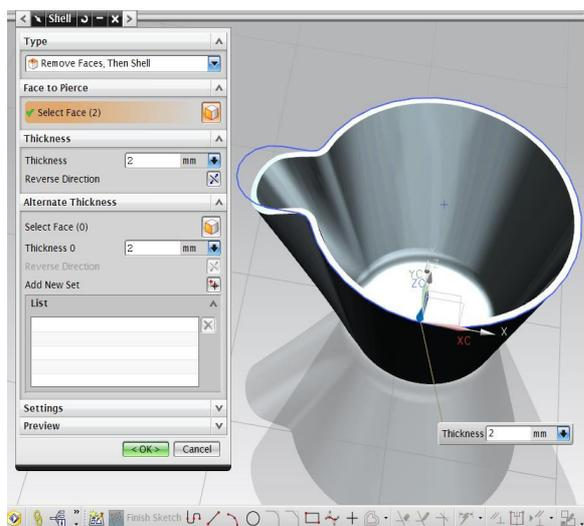

Fig. 5 "Shell" control window

From this moment generating 3D model is

complicated because some areas of geometric complexity well above average must be defined. Basically it is the rib edge of the mouth mask piece. For this objective, use is made of the following combined controls: "Swept", "Insert Point", "Through Curve", "Sew" and "Patch". Dialogue sections of control "Swept" are: "Sections", "Guides", "Spine", "Section Options", "Settings menu" and "Preview". All these sections and how to apply them on the nebulizer body are shown in Figure 6.

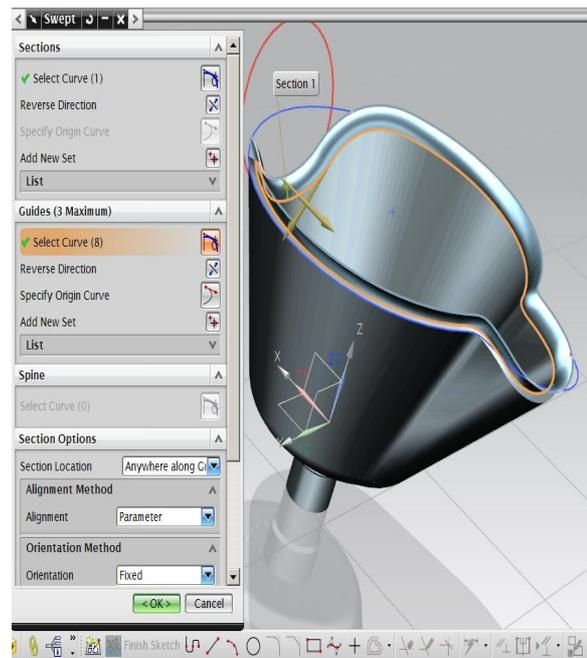

Fig. 6 "Swept" control window

For the successful implementation of this control, a draft sketch should be first made in which to determine by control "Insert Point" of Module Drawing, two points of intersection of the symmetry plan selected by the space curves defining the upper edge of the mouth mask. The result is shown in Figure 7. Also in this sketch number 25, two arcs are drawn that will be used to generate the two marginal areas with the control "Swept".

#### 4. RESULTS

Implementing the two surfaces with the control "Swept" and the third one with the control "Through Curve" results in a cavity bounded by three surfaces to be sewn with the control "Sew" to transform them into a single one. The "Sew" control window and the result of its application are presented in Figure 8.

Finally, the solid generated will be patched with the aforementioned cavity bounded by a single surface and a single solid will result due to the setting required by control patch". The final result after applying the connection

controls of "Edge Blend" type is presented in Figure 9.

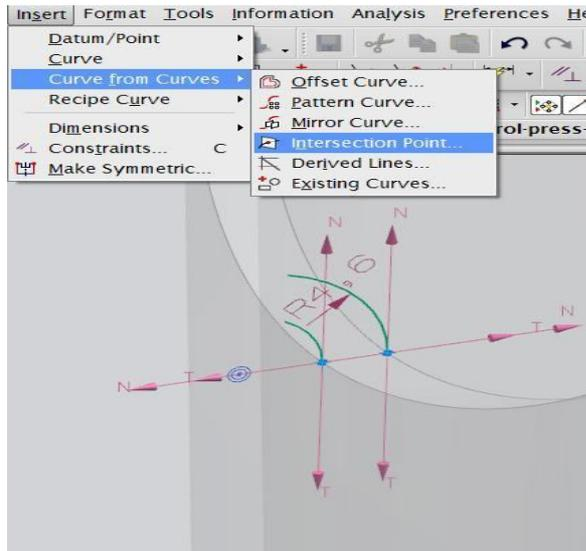

Fig. 7 Obtaining the two intersection points

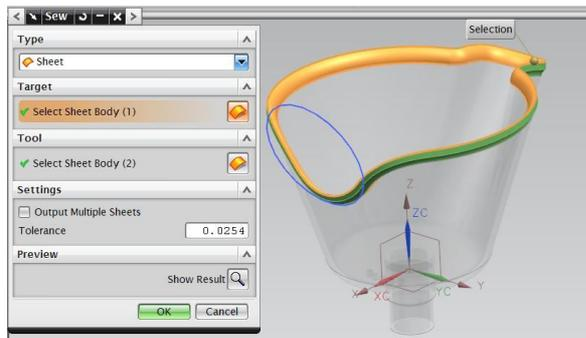

Fig. 8 “Sew” control window

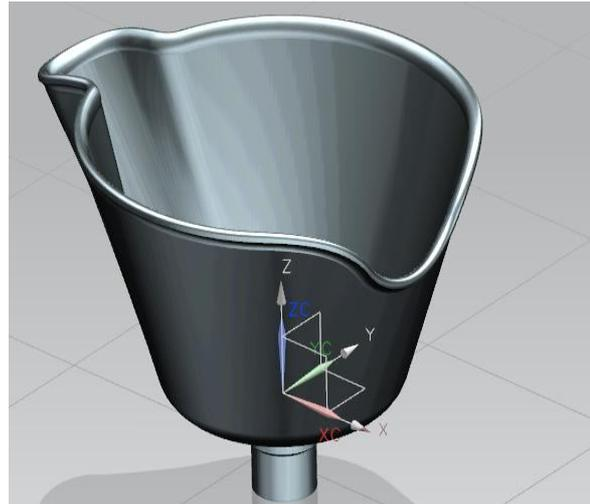

Fig. 9 3D result of the modelled accessory

### REFERENCES

- [1] **Haraga G.** “ *Mathematical and Virtual Modelling of a Spur Gear*”, Proceedings of the 10<sup>th</sup> International Symposium on Science of Mechanisms and Machines, SYROM 2009, Ed. Springer ISBN: 978-90-481-3521-9, October 12-15, 2009, Braşov, pp.159-169, ISI Web of Knowledge, Indexed ISI Thomson <http://www.springer.com/engineering/mechanical+eng/book/978-90-481-3521-9>.
- [2] **Haraga G.** “ *Applications of CAD systems*”, ICEGD 2009 - International Conference on Engineering Graphics and Design, Series Applied Mathematics and Mechanics 52, Vol.Ia, ISSN 1221-5872, pp.291-294, Technical University of Cluj-Napoca, Acta Technica Napocensis, 12-13 June 2009.
- [3] **Haraga G.** “ *3D Modelling a truck using Solid Edge*”, The Annals of “Dunarea de Jos” University of Galati, Fascicle XIV, Mechanical Engineering, CNCSIS code 220, „B+”, Indexed Journal BDI-CSA (Cambridge Scientific Abstracts) ISSN 1224-5615, pp.96-99, 2006, <http://www.ann.ugal.ro/im/2006.htm>