

NEW MATERIALS AND PRACTICES FOR BRICKWORK TIP "TORPEDO" POT

Adrian VASILIU

"Dunarea de Jos" University of Galati
e-mail: avasilu@ugal.ro

ABSTRACT

Nowadays, pots, besides transport operations and liquid metal desulphurization perform functions of dephosphorization. Intense refractory brickwork is required, and in such cases, it is recommended that the performance refractory materials are used. This paper presents a case analysis on modernizing transport ladles or "Torpedo" pot in order to increase service life.

KEYWORDS: iron pots, masonry degradation, new materials

1. Introduction

Steel industry is one of the industrial activities, consuming fuel, which had to reduce their consumption by streamlining the process flows. So, it occurred and it manifests currently worldwide trends towards implementing in production technologies, aggregates and machinery thermo, raw materials, characterized by efficiency and performance, with the ultimate aim of reducing specific consumption of fuels and reduce energy losses to the environment.

Integrated steel mills are used to transport iron to the steelworks blast furnace with pots of different shapes: pot with a spout, pot - type mixer and Torpedo ladles. Whatever form for transporting hot metal ladles, they are made of sheet steel riveted or welded and are lined with refractory brick.



Fig. 1. Assembly wagon - Torpedo pot

Of the various construction types, depending on the furnace capacity and transport distance, ArcelorMittal Galati, was chosen type Torpedo ladles 300-ton capacity. These pots are mounted on

carriages C.F. special type of tread must withstand high loads.

Torpedo type pots are placed horizontally cylindrical shape with tapered ends. At the upper metal shell is provided with an opening for loading and unloading. The body of the pot rests on two platforms C.F. through two rotating axes that allow the pot to download. On one of the two platforms are mounted rotating devices. The body of the pot along with the two platforms, "wagon pot Torpedo" (Fig. 1).

Refractory materials used in building up the pot must withstand temperature liquid metal erosion mechanical abrasive action of the metal to flow into the pot and transport, chemical action of foam and temperature variations. Of liquid iron pots Torpedo download body by rotating the pan in a pot of transfer (transmission) sitting on a transfer car, where the bridge crane is downloaded directly into the inverter.

2. Objectives

This paper presents an analysis of the degradation and destruction builders liquid pig iron transport ladles type Torpedo. Based on this analysis and new functions met, this type of pot requires revision of classic refractory materials used so far and the use of new materials with specific properties superior.

Integrated steel torpedo cars are used for transporting molten metal from the furnace to the steelworks. Each car has a torpedo-shaped pot, which can carry up to 250 tons of liquid metal. The pot is lined with refractory brick to maintain the contents of the liquid and to protect the external steel casing.

Volatility and erosive nature of molten metal has to be monitored for the torpedo car, this maintenance function of the refractory lining being vital. Following a breakout is significant in terms of safety and cost.

Benefits of the system Torpedo measuring machines Land:

Avoiding Breakout and its consequences - time, materials, labor through:

- automated process - saves costs and time man;
 - historic thermal image database on both sides of each car;
- Analysis of the data over a long period of time can reduce the cost and:
- Improve safety;
 - Improving confidence in refractory status and safety of cars by planned programs for refractory relining and maintenance.

3. Theoretical considerations

Transport of hot metal from blast furnaces to steel mills or M.T is made with iron pots. Sometimes these pots, in addition to the role of transport, have the sole of storage for short periods of liquid pig iron.

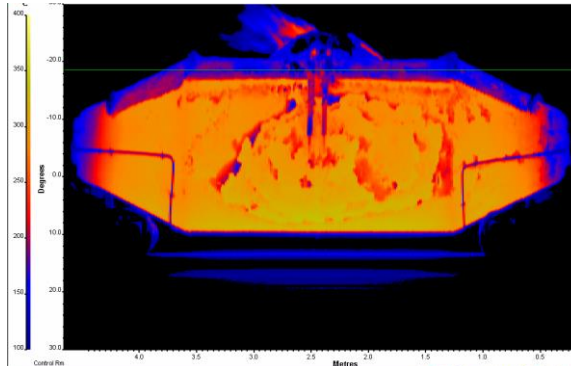

Fig. 2. Infrared scanning Torpedo type pot

Choosing the appropriate refractory linings execution iron pots, it is subject to a number of factors physicochemical nature of thermal and mechanical. Besides temperature of 1300-1350 °C, there are other applications which alone or together are more important.

Chemical corrosion to slag temperature drop (load pots), mechanical shocks due to load iron jet rotation, erosion and abrasion molten metal are essential to choosing refractory necessary.

The action of chemical corrosion is due to the chemical nature of hot metal and slag. Most blast-furnace slag is characterized by reports CaO/SiO₂ contained within 1.0-1.3 and (CaO + MgO)/(SiO₂ +

Al₂O₃) from 0.85-1.20. The attack is manifested by slag penetration and corrosion of masonry joints.

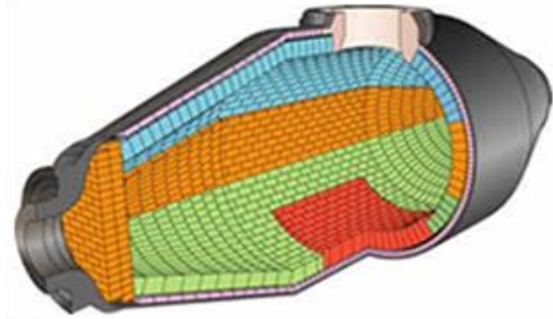

Fig. 3. Infrared scanning Torpedo type pot

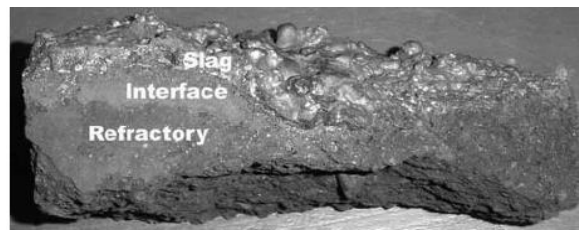

Fig. 4. Chemical adhesion slag - refractory [1]

Refractory corrosion is a very complex process and is described by three factors:

- *dissolution*, or diffusion, is a chemical process in which the refractory material is dissolved or goes slag.
- *penetration*; it is a physical-chemical process and is manifested by entering masonry slag and corrosion, especially on the joints causing mechanical stress in masonry.
- *abrasion* occurs due to movement of hot metal, loading and unloading, but especially to transport and produce phenomena of abrasion on refractories.

Dissolution of refractory material in liquid slag is usually expressed in terms of dissolution rate, which shows what percentage of saturation of the slag, the process is balanced and does not occur. It is known that the highest rate of the dissolution process is controlled by solid liquid mass transfer, given by equation (1):

$$-\frac{dr}{dt} = A_0 \cdot U^b \quad (1)$$

where:

- r is the radius of the interior [m];
- t is the time [s];
- A₀ is a constant specific to conditions;
- U is the peripheral speed of rotation;
- b is a constant.

The rate of dissolution is given by the equation:

$$v = k \cdot (n_s - n_b) \quad (2)$$

where:

- v is the rate of dissolution;
- k - coefficient of mass transfer;
- n_s, n_b - oxide interface slag / refractory.

Slag resistance of refractory bricks to be determined primarily by the equilibrium relationships. It is clear that a slag, which is already saturated with a solid phase still, cannot attack a refractory product.

The thermal shock that occurs when loading and unloading the pots causes destruction of the brickwork, the occurrence of cracks or dislocations bricks. The phenomenon is more serious as the temperature gradient is higher and the number of heating cycles is higher.

4. Torpedo ladles iron masonry

ArcelorMittal Galati iron pots of 300 tons, Torpedo type were lined with indigenous materials, silica-alumina FA85, D82, EC79, CA75, C71 (STAS 1580 / 3-81).

Table 1. Features refractory

Characteristics	STAS				
	270/81		1026		136/81
	FA85	EC79	D82	CA75	C71
Content Al_2O_3 [%]	80	65	60	40	-
Content Fe_2O_3 [%]	1.0	1.5	2.1	2.5	-
Refractoriness [I.P]	185	179	182	175	171
Porosity apar. [%]	23	23	22	22	22
Thermal shock	10	10	-	20	15

To increase sustainability by about 30% silica alumina liners, they are impregnated with liquid tar. Heated to 1200 °C it is absorbed by the pores of the bricks and the free residual water by evaporation from the mortar of the connection between the bricks. By burning in a reducing atmosphere at ~700-800 °C, tar is produced, and cracking is accompanied by a separation of carbon forming a carbon skeleton, resistant to high temperatures and mechanical wear.

Isolation pots run with pleasant I 79 having refractory capabilities, additional caps sit in the compressible layer of insulating concrete aluminous (BTIA) 78-79 mm thick. The discharge pots refractory concrete is made with hard super aluminous BR94.

Torpedo pot having the role of transport and storage for short periods of cast iron pot of operation is simple. The charge brings Torpedo ladle car port

under the discharge spout of the furnace so that the jet of liquid iron pot to flow through the spout.

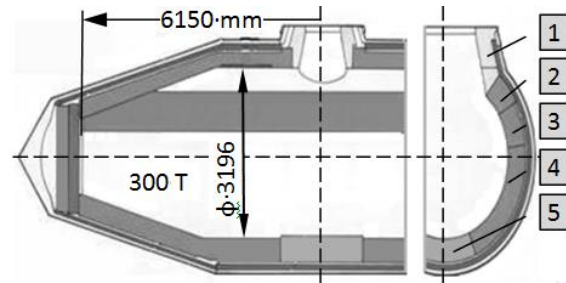

Fig. 5. Masonry pot 300T (current situation) 1- BR94; 2-FA85; 3-D82; 4-EC79, 5-D82

The torpedo liquid iron pots download their content by rotating the pan in a pot placed on a transfer car, from where, the content, will be downloaded directly into the inverter. The technical features are:

- Nominal Capacity: 300 tons;
- The distance the buffers 27500 mm;
- Total weight: 640 tons loaded;
- Ladle length: 12300 mm;
- Diameter: 3196 mm.

In order to increase the life of Torpedo, ladles of iron transport in the new operating conditions superior refractories must be used.

5. The causes of refractory linings wear

Given the role of transport and storage for short periods liquid pig iron, cast iron pot operation is simple. To make car charging port to download cast iron trough furnace, the flow of liquid iron in the pot is directed to flow through the spout. Avoiding falling jet of liquid iron directly on a metal sheath, the degradation and decommissioning of the pot is prevented.



Fig. 6. Charging hole (mouth) 300T casting ladle after 1020

In the loading-unloading mouth, where mechanical wear due to jet iron is high, the wear layer which is over a length of ~1 m on both sides of the mouth is made of FA85 PLS6 format bricks, PLS7 having a thickness of 300 mm.

At pots 300T Torpedo type change ring at the mouth of loading - unloading is done by loosening the cap and replacement piece shaped refractory (Fig. 7).

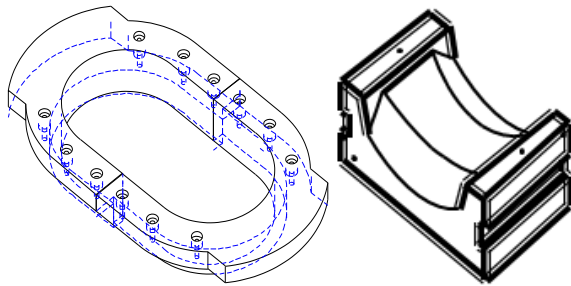

Fig. 7. Fixing ring and lantern refractory

The Torpedo liquid iron pots are downloaded by rotating the pan in a pot of transfer (transmission) sitting on a transfer car, where the bridge crane is discharged directly into the mixer or converter.

The movement of liquid pig iron in the charge inside the pot causes erosion and abrasion of refractory, leading to a decrease in the thickness of the refractory lining (Fig. 8).

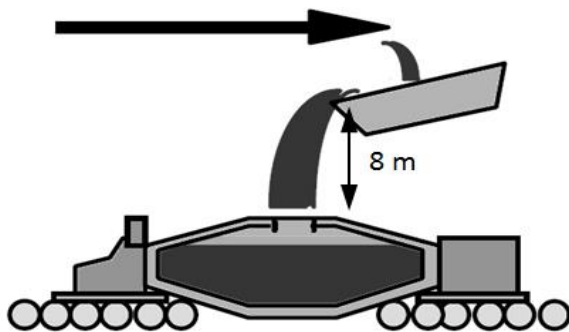

Fig. 8. Download iron liquid in the pot

Flushing phenomenon can be avoided by filling the pot at normal capacity and by draining of iron. Gradients in temperature are induced in the resistant during filling and emptying the pot, ring masonry destroyed by thermal shock when the brick refractory was exposed to the hot iron casting in the pot, due to the phenomenon of thermal expansion (Fig. 3).

The crack at the ends of the horizontal surface of bricks induced sudden contraction as a result of contact with ambient air, after emptying the pot.

In many cases, the various slagging and deposits (bears), chemically or mechanically adhering the refractory lining, the cleaning and detachment causes degradation or destruction of masonry.

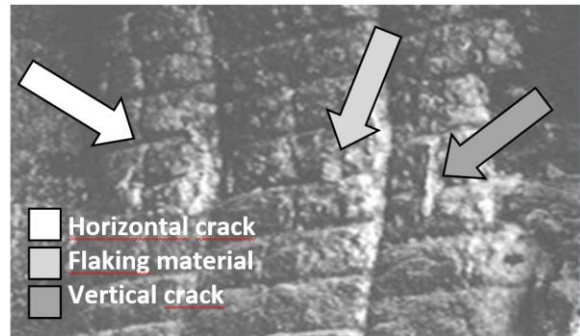

Fig. 9. Masonry degradation - thermal shock

6. Refractory news

Modern technology provides a number of metallurgical operations to be performed on the discharge spout cast iron pot or transport. Therefore, torpedo containers are used no longer just for transport but also to perform functions for the treatment of hot metal, such as desulfurization or dephosphorising (Fig. 10).

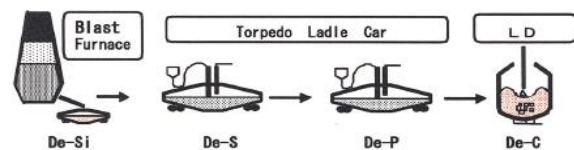

Fig. 10. Treatment of hot metal pot

These practices involve high temperature, turbulence of the bath metal/slag by the injection of the reactive streams and a high chemical attack by the slag on the refractory lining. Therefore, the life of the solutions listed above like "bricks impregnated with tar" is outdated, alumina being reduced dramatically.

In order to increase the life of Torpedo ladles of iron transport in the new operating conditions, there must be used superior refractory and differentiated embedding pot on demand.

Thus, refractory products recommended to be used for Torpedo type cast iron pots are:

- Silica-alumina;
- Alumina (Al_2O_3 65%, 50% Al_2O_3);
- ASC (aluminum - silicon - carbon);
- AMC (aluminum-magnesium-carbon);
- Mortars and concretes, inclusive.

The experimental results have shown that the resistance to molten slag of Al_2O_3 , spinel, depends mainly on the amount of converted spinel containing 75% Al_2O_3 by weight [3].

As apparent from the graph in Figure 11, Al_2O_3 -MgO cast is able to resist much better to attack slag

(penetration and corrosion) compared with Al_2O_3 -spinel.

Worldwide there were made a series of tests with good insulation refractory fiber pots with 45% Al_2O_3 in thickness of 10 to 30 mm.

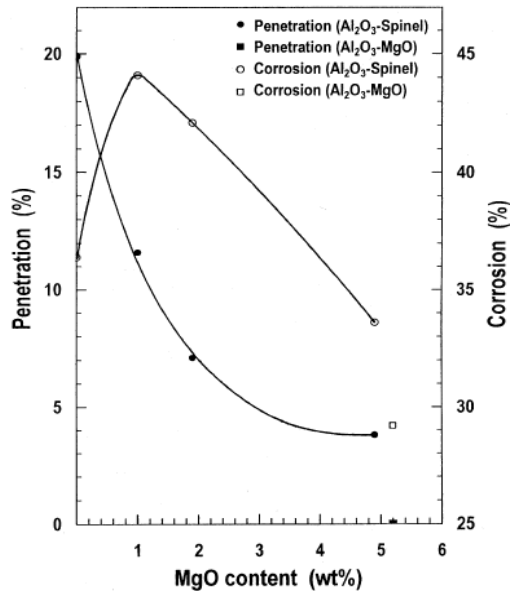

Fig. 11. Resistance to slag attack [3]

Refractory lining of Torpedo ladles type consists of a layer of insulation, a layer of duration and a wear layer (Table 2, Table 3).

Table 2.

Refractory material	Zone	
	slag	impact
	[mm]	[mm]
Bricks ASC (5/10%SiC+10/15%C)	275	382
Poured concrete (65% Al_2O_3)	20	20
Bricks (50% Al_2O_3)	70	70

Table 3.

Refractory material	Zone	
	cylindrical	conic
	[mm]	[mm]
Bricks (75% Al_2O_3 +22%SiC+%C)	275	382
Poured concrete (65% Al_2O_3)	20	20
Bricks (50% Al_2O_3)	70	70

The discharge pots are made of alumina-carbon $Al_2O_3 + 22\% SiC$ (Figure 12).

For the loading mouth, a method was adopted for work implementing by shotcrete material. Alumina-carbon which is based on silicon carbide and bauxite as main raw material was used, which is

bound with cement or micro-dust, and non-adhesive slag with high strength and resistance corrosion.

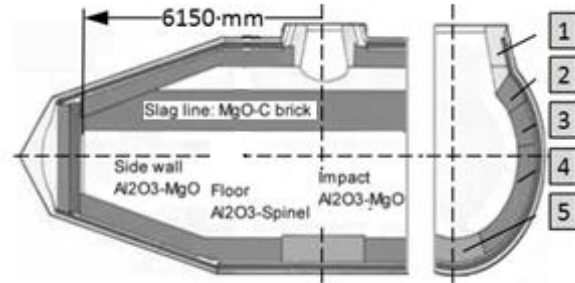

Fig. 12. Laying pot 300T (proposed situation) 1- Al_2O_3 -SiC; 2-MgO-C; 3-5/10%SiC+10/15%C; 4-75% Al_2O_3 +22%SiC+%C; 5- Al_2O_3 -MgO



Fig. 13. Loading mouth area

Cast iron pots can be removed from circulation before performing the normal operating cycle, only with the recipient section in the following situations:

- the occurrence of uneven wear and delivered to a depth of more than half the thickness of wear;
- bricks dislocation in certain areas;
- it finds the broken bricks, with deep cracks wider than 2 mm;
- when joints between bricks are weathered and appear exaggerated due coking iron and slag area.

In refractory brickwork iron pots not leave an expansion joint, which is taken from the metal sheath of insulating layers and plastics.

7. Conclusions

Increasing availability of transport iron pot Torpedo wagon can be achieved by:

- Reducing heat loss through the walls of the pot, using as insulating refractory ceramic fiber (45% Al_2O_3 10 to 30 mm);
- Resistant to thermal shock lasting refractory layer type ASC (Al_2O_3 -SiC-C);



- The decrease of penetration and corrosion-MgOAl₂O₃ brick type;
- Reduce slagging and crusts, adhering mechanically or chemically on the refractory lining.

Reduce the number of stops for repairs in the outlet by using a removable ring - shaped as a ceramic piece.

[2]. **Chen Y.**, *Slag Line Dissolution of MgO Refractory*, Canadian Metallurgical, vol. 44, p. 323-330, 2005.

[3]. **Deică N.**, *Utilizarea rațională a produselor refractare*, Editura Tehnică, București, 1982.

[4]. **Kronthaler A.**, *Raw materials for refractories – a strategic challenge*, Interceram – Refractories, Special Edition, 2009.

[5]. **Rău Al., Trișța I.**, *Meturgia oțelului*, Editura Didactică și Pedagogică, București, 1973.

[6]. **Avram C., Bob C.**, *Noi tipuri de betoane speciale*, Editura Tehnică, București, 1980.

References

[1]. **Hady Efendy et al.**, *Molten Metal-Slag-Refractory Reactions During Converting Process*, International Journal of Engineering & Technology, IJET-IJENS, vol. 10, no, 3, p. 52-54.