



PERFORMANCE MANAGEMENT SYSTEM FOR PURIFYING POLLUTED INDUSTRIAL WATER

**Stefan DRAGOMIR, Georgeta DRAGOMIR
Marian BORDEI**

"Dunarea de Jos" University of Galati
email: ddragomir@ugal.ro

ABSTRACT

In this paper we show an integrate system of water management and an efficient solution that is a floating dock, placed in the harbour area. Water quality is one of the most important elements for life support and contributes to the sustainable development of human society. Following the technical and economic transformations taking place in industry, the waste water remediation system required new approaches to management in this area. It recorded an increase in the variety and complexity of the types and quantities of waste generated in the last years and for administration of this situation are necessary new methods and equipments of waste neutralisation or its transformation in raw materials for industries of profile.

KEYWORDS: management system, cleaning water, polluted water, shipyard

1. Introduction

Water management, in accordance with the European request, has the duty to improve the ways to eliminate all substances which pollute the water sources in a considered location (plant, enterprise, in urban or rural area).

Water management is the activity of planning, developing, distributing and optimum use of water resources under defined water polices and regulations. It may mean:

- management of water treatment of drinking water, industrial water, sewage or wastewater;
- management of flood protection;
- management of the water table. Water supply and the cleaning system are the most critical part for good water management and high yields. Often the water supply is experienced as the most critical part of the water management system. As a cure for the insufficient water supply the control structures are closed. However this will work counter-productive, because it will decrease percolation and consequently increases the toxicity levels in the field. The system should aim at increasing both water supply and improving drainage.

The Water Management system consists of three important components:

- a proper operation of the drainage system should benefit the yield levels and the potentials for crop diversification. The water management should

aim to promote the ripening of the soft soils by permitting the drying of the surface layers during the dry season. Deep plowing followed by intensive puddling for land preparation will benefit the yields.

-traditional developed areas usually have a well organized institutional infrastructure. It are usually the more difficult to operate areas where there are problems. Lack of understanding to apply the proper Soil and Water Management system and the lack of Operation & Maintenance budget and facilities are the key limitations for improvement [1].

The flows should be able to flow for drainage as well as for supply, depending on the needs of human communities. That could include leaching of toxic elements. Also the type of crops and the rainfalls and land elevations against flood levels determine if drainage or supply is required. Double connection always means need for water system control including control of hazard of "over-drainage".

The South East Region for Waste Management Plan (SERWMP) is composed of several sections showing the current situation in the region, objectives, alternatives for treatment and final methods of determining the minimum cost. In short, it includes the current situation that presents information on the current situation on waste management in the South Region:

- objectives and targets relating to regional waste management: sets targets to be consistent with national and EU objectives;

-forecast on the generation, collection, treatment, disposal, recycling and minimize quantity of waste: provides generation, collection, treatment, recycling and waste disposal, taking and investment and implementing actions to be undertaken;

-assessment of possible technical alternatives: study various technical alternatives that may be considered for the collection, recycling, treatment and disposal of waste;

-benchmarking: contributes to the choice of the lowest cost scenario for waste water management;

Assess the degree of supportability by people: take into account operating costs, financing and investment, including costs necessary to support implementation of grant schemes - implementation of measures SERWMP.

Implementation measures include a list of actions planned to allow the regional Plan, relating to a reduction in the amount of biodegradable waste and packaging of municipal solid waste, an investment (equipment, utilities) a measure of training and preparation for an awareness and public participation continue a financial measures, incentives and tools, legal measures.

2. Theoretical elements about mechanical cleaning

Mechanical cleaning methods ensure that the sewage of large bodies circulating in the impurities which are deposited and those floating or can be brought into an area and then processed. The method is generally used as pre-filtering or purifying single (final), depending on the degree of cleaning required,

as should be followed or not by other purification steps. The mechanical cleaning step is to retain matter occur and fine. For their detention are used grills, slipped for fat materials, equipment for separating the sand from water and installations for decanting substances with a high density of water.

According to interstitial size, grills can be classified as follows:

-rare grills bars (used to capture paper, cardboard, plastics bodies, diverse fiber of materials etc.), have the gap of 40 - 50mm (and sometimes 100mm) between their bars. Bars are inclined at 1/3, and the speed of water flowing that through the grill bars is maintained at 60 - 100cm/s, in order to avoid the deposition of waste on the bottom of the deck. The materials retained on the grill drop on the bottom of the deck and can be manually cleaned although it is preferable to to this operation mechanically. These materials are discharged as such to be deposited into landfill or incinerated. In some cases the recovery materials can be shredded by cutting in 0.5 to 0.1mm pieces. The shredding machines are installed directly into the floating dock close to the land, so that the disintegrated matter can pass through the grill and can be discharged at the same time by using a mobile carrier on the land. So, in general, the cleaning of the grill bars can be done manually or mechanically. Manual cleaning is used for smaller plants, with small quantities of materials accepted. Raking is made by hand on a platform situated above the maximum level of the water. Mechanical cleaning is used when the quantities of materials that are retained are so great that frequent cleaning or continues racking are required.

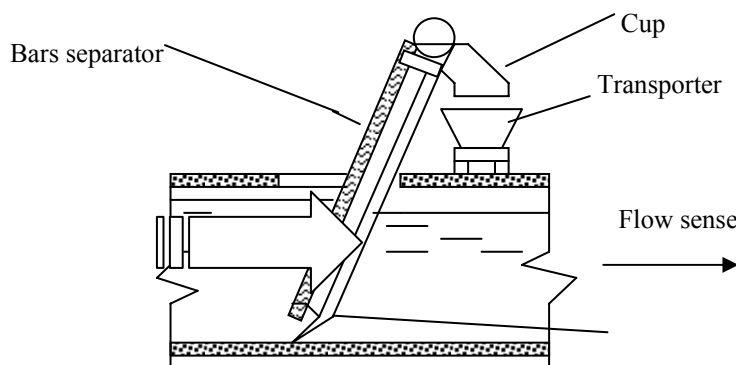

Fig. 1. Automatic cleaning system with motion rack

There are a lot of grill types with different mechanical cleaning systems of the water in the floating dock. For example, in a 4m depth floating dock cleaning rotary racks can be used. At greater water depths, straight grills are used, and racks with translation motion (Fig. 1) are used for cleaning. After grill size and degree of mechanization adopted for the cleaning station, deductions from barbecues

can be moved mechanically, hydraulically or manually sorted to recover ferrous materials. The nonferrous materials and organics and composted or incinerated. Granulation and cutting material retained on grills can be made with plants placed in water or power outside it. Facilities installed in the water current advantages of a hygienic - sanitary. The material grinding in the water current is done with

shredder equipment. At low and medium flows, they are mounted so that the whole current of water passing through the chip, and thereby to be large bodies crumble. For small quantities of waste, shredder is mounted near the grill that has horizontal bars and mechanical cleaning with rotary rake [2]. In this case, the deductions from grill are collected by a rake with rotating vertical shaft rotation and transported laterally to the machine for waste grinding material positioned below the water.

3. Original solution for fats separation performing equipment

The fat separator may use to remove natural impurities or flotation or flotation with air. Flotation

is carried out in natural ponds routine in which, because of the small gears that move water, light particles rise to the surface.

Air flotation may be low pressure or under pressure: in the latter case of air bubbles entering the water adheres to the material in suspension and help reach the surface of the liquid or solid colloidal particles in the mass.

Flotation is used as additional purification step before biological purification of water.

For cleaning industrial wastewater, flotation is used in many cases, for example, water from the oil industry, mining, food, especially when sewage must be treated biologically, either separately or together with other sewage.

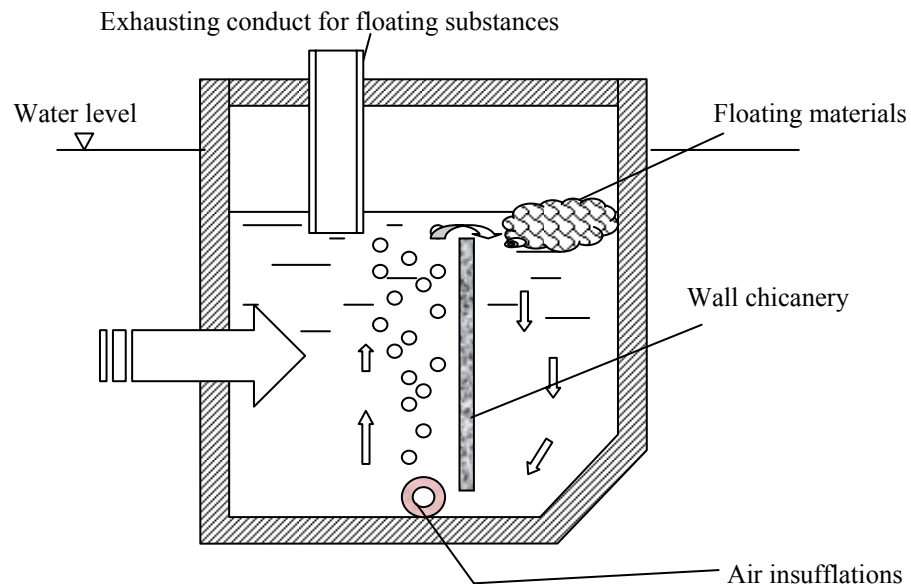

Fig. 2. Section through floating dock and schedule of waste separation

The use of flotation and removal of heavier particles from water is too very important.

The restraint is the nature of fats and namely:

- fat free, that tend to raise the water surface;
- fat soaps, in the colloidal dispersion or in the form of emulsions, which do not naturally tend to rise to the surface;
- tars, which tend to lodge.

To the fat in the first group, the method based on decreasing the rate of flow of water, fat distinguishing the surface in an area arranged for this purpose. Greases from the second group, pools are formed in three sections. In the central basin is insufflations of air and separation of fats, which are directed to collecting trough water and then is discharge in the lateral compartment (Fig.2).

The main parameters for fat separator are:

- time parking: 5 - 10minutes;
- the quantity of air: 0.2 - 0.8m³ air/m³ water;
- water depth, 1.20 – 2.75m.

An interesting device for the separation of fat that is combined with air injection vacuum maintained afloat by a vacuum pump. For this purpose it uses a pool covered airtight. For an efficiently purify of water should be introduce an air flow at half from floating dock.

Air bubbles that formed rise to the surface and take after them floating materials and decanted easily. Layer of foam is formed which is collected by a blade that leads to the mouth of the exhaust.

4. Measurements and results

Decanted material is deposited on the bottom of the basin, where they scrape by and discharged. Before and after the cleaning operation we take samples of water and in our laboratory we analyzed these samples. We can see the result of this measurement in the Table 1.



Table 1

No.	Quality indicators	NTPA 001- National and European standardized	Maximum acceptable level		
			Recorded before water cleaning	Recorded after water cleaning	u. m.
1	Temperature	25	25.5	25	°C
2	pH	6.5 – 8.5	8.8	7.9	unities pH
3	Suspension in water	35	300	57	mg/L
4	CBO ₅	20	300	18	
5	CCO - Cr	125	500	117	
6	ammonia nitrogen NH ₄ ⁺	2	30	4.2	
7	nitrogen total N	10	14	11.5	
8	Sulphides and H ₂ S	0,5	1,2	0.7	
9	Phosphorus	1,0	5	1.8	
10	Synthetic detergents	0,5	26	8.2	
12	Substances extractable	20	30	19	
13	Total iron ion Fe ²⁺ , Fe ³⁺	5.0	-	3.7	
14	Total Cyanide	0,1	1,6	0.16	
15	Nickel, Ni ²⁺	0,1	1,2	0.14	
16	Chromes trivalent Cr ³⁺	1,0	1,8	0.9	
17	Chromes hexavalent Cr ⁶⁺	1,0	1,1	0.8	
18	Copper Cu ²⁺	0,1	1,5	0.19	
19	Chlorides Cl	500	584	483	
20	Phosphates PO ₃ ⁻	1	3,2	1.4	

To investigate potential issues in improving the quality of life for residents of Galați city and surrounding region and reducing pollution levels in the Danube River and its downstream locations it is necessary to implementing an automated monitoring system of water parameters, which integrates satellite images using GPS technology.

The main indicators of quality of water, the limits of detection, and the most used methods of analysis is shown in table no.1. In this table are given standardized methods nationally and European (third column) and in the next columns the results recorded before and after using the floating dock for cleaning operation. For determined the parameters of water quality we used own laboratories equipped with these techniques of analysis, such as:

- ionic chromatography (IC);
- atomic plasma spectrometry (APS);
- atomic absorption spectrometry (AAS);
- gas chromatography (CG);
- chromatography liquid high-pressure (HPLC).

Statistical Processing permits a better interpretation of the parameters evolution according to specialists will is performing. Data acquisition for water parameters developing, permit to compare the pollution waters water parameters at precisely time periods.

A specialized computer controls the system that have instruments and devices for coupling at measuring interface, based on real information about

quantity of diverse substance dissolved in water samples.

This automated monitoring integrated system must to give information for decisional support and for the measurement that can be taking.

This equipment can decanted the most of the substances in suspension in sewage. After the direction of flow of water decanted equipment are divided into: horizontal and vertical. After the section the decanted equipment may be rectangular (rarely square) and circular.

In terms of processing noted in mud decanted, they can share the space without decanter fermentation (fermentation is done in separate building), or with floor decanter (Imhoff or Emscher), including spaces and fermentation [3]. After place it occupies in the scheme of purification, they are divided into: primary decanter (placed before biological cleaning step) and secondary decanted (after biological cleaning step).

Channel to collect deposits from the upstream head is several times daily to prevent fermentation of using the hydraulic or mechanical means.

Vertical decanted equipment have circular cross section, less square, in which water circulates from the bottom up with a speed Ascension of about 0.7mm/s. The water enters the decanter through a central tube provided at the bottom with a deflection for a more uniform distribution and exits at the upper side over a circular overflow. During normal station



is 1.5 h. Removal of deposits is done by a hydraulic tube vertically on differential pressure [4].

Chemical cleaning is more known as chemical-mechanical cleaning, since it is preceded, in most cases, mechanical cleaning facilities presented above.

Chemical-mechanical cleaning is done in a whole building that includes:

- the construction preparation, determination and introduction of coagulation reagents in treated water;
- decanted.

For mechanical and chemical reagents are used for removal by coagulation and flocculated dispersed fine material and the colloidal.

A colloidal suspension consists of extremely small particles, which possess certain surface with electrical charged. The electrical load induces rejection force. This is of a force between neighbouring particles, which explains the great stability of these suspensions. If, by any means whatsoever, for example, changing the pH or the introduction of a colloid electrical load, it fails to cancel or reduce partially the tasks of electrical particles in water filter, these particles are formed and crowded precipitated relatively bulky (flocculate) capable of rapidly decanted.

5. Conclusions

Precipitation agents most widely used for urban effluent is ferrous sulphate and ferric chloride. Usual doses coagulants used are about 35g/m³ of water for ferric chloride, and about 55g/m³ water for ferrous sulphate, which may vary from case to case.

The action of ferrous sulphate at a pH between 6 and 7 (sometimes 5), ferric chloride on the contrary, at alkaline pH is very important. In some cases, precipitation (flocculate) and are hampered by variations in pH, temperature or low level of water do that the floccus results that are very light and make hard. In such cases, a good factor that activate the flocculated process is silica, an element that helps prevent electrical tasks and to obtain a compact precipitate.

Separators pools of flotation aimed at removal of waste water to oils, fats and, in general, all substances lighter than water, which rises to the

surface, in quiet areas and low horizontal velocity water. Fat separators mounted, after equipment for separate the sand from water are located where the drainage network has been built into the system unit and after bars grill, when the network has been built into a complex system.

Other substances that can activate the flocculated process are tannin, some clays etc... The coagulants involves in water treatment with a good mastery and knowledge of flow treated. Also, depending on the coagulant, it is necessary a pH of the water that is cleaning.

The time required for reaction with coagulants sewage is 10-20min., a process that occurs in specific basins, to cavil, which provides a mixture intimae. Sometime these pools are replaced with the reaction chamber, where mixing is provided by agitators with large water based and where 15-30min.

Using coagulants is producing a volume of decanted sludge 2-3times higher, than the result from decanted process without coagulant.

The process of chemical treatment of water is falls between simple decantation and biological cleaning. By adding disinfection can sometimes achieve by this method, the efficiency of the biological step. The flocculated process can be doing in separately floating dock or in commune tank with decanted equipment. This equipment is part from new strategy of water management that shipyard administration must do in practice. Sing of floating dock like separated and cleaning system, have the advantage that he avoids the cracked of floccules and their dispersion and too all dangerous substances from waste water are eliminate.

References

- [1]. Tchobanoglous, G., Burton, F.L., and Stensel, H.D. - *Wastewater Engineering (Treatment Disposal Reuse) / Metcalf & Eddy, Inc.* (4th ed.). McGraw-Hill Book Company. ISBN 0-07-041878-0, (2003).
- [2]. Beychok, Milton R. - *Aqueous Wastes from Petroleum and Petrochemical Plants* (1st Ed.). John Wiley & Sons. LCCN 67019834, (1967).
- [3]. *** - *International Journal of Water Resources Development*, ISSN: 1360-0648 (electronic) 0790-0627 (paper).
- [4]. *** - *Journal of Water and Health*, ISSN: 1477-8920, IWA Publishing.