



SOFTWARE USED AT CASTINGS PRODUCTION

Ioan MARGINEAN, Constantin BRATU,
Sorin-Adrian COCOLAS
Politehnica University of Bucuresti

ABSTRACT

The foundry industry has been developed worldwide, a number of software that can assist the design work and various processes in the production of castings. Current usage of such software by metallurgical engineers is possible after a few days training, advanced computer knowledge is not required. Also, the simplicity, performance that can ensure the sales prices and that does not require powerful software equipment is the main advantages of these programs.

KEYWORDS: foundry industry, software, casting

1. Software Foundry Industry

It should be noted that these programs and computer in general, do not replace the "man" factor. Technology is thinking how to do technology. The used computer program supports the designer by making calculations for sizing and optimization are much more accurate and are obtained in a much smaller, making it possible to decide whether a design is correct or not. Using the soft prevents the execution of design errors that lead mostly to attainment of the required technical performance.

These professional programs to simulate various phenomena occurring during flow and solidification of cast can be changed to simulate different methods of casting. Mathematical models of these programs differ in principle by introducing additional conditions that arise due to their use in the solidification simulation for the various processes of casting. Simulation programs are generally intended for simulation of thermal fields in solidification of cast.

Conditions to limit allowed by the software may be:

- *type Diriclet* when considered as input data to the surface temperature of ingots or castings;
- *Neumann type* when considering the input heat flux of the considered border segment, such as radiation or external sources of heat;
- *Cauchy type*, it is considered as input data as well as the outside temperature coefficient of heat exchange between the global environment and system analysis.

In general, the basic structure of the program, which was conceived and developed in a structure

with multiple user options, distinguishes the following stages of work:

- automatic mesh (the graphical) of castings in volume elements;
- determining the type of coordinates used;
- enter the number of areas of different materials;
- introducing thermo-physical material characteristics for each area;
- placing temperature of the mixture of hardware and training;
- introduction of the surface temperature shrink head or mold;
- introducing of time step and total time simulated;
- the graphical representation of temperature and solidified areas.

General use of software provides a convenient way of operating through a menu system which can call their main functions as handling input and output files; mesh domain analysis; enter the material; introduction of casting temperature and initial temperature; placing conditions on the surface heat exchange system analysis; implementation of the program and other.

2. Software Process for Simulation and Optimization of Solidification of Castings with Different Procedures

2.1. NovaFlow & Solid CV Gravity

NovaFlow & Solid CV is a complete mould filling and solidification simulation package based on advanced fluid flow and heat transfer theories. NovaFlow & Solid CV utilizes Control Volume

Meshing technology (CVM). With this technology, the surface of the 3D model controls the shape of the mesh elements on the border of the casting. This creates cubic elements inside the casting and border cells on the boundary of the casting. This program simulates most of the casting methods on the market such as: gravity sand casting, gravity permanent mould, low pressure die casting, high pressure die casting, lost wax method, tilt pouring and lost foam process. All commercial alloys can be simulated such

as: grey and ductile iron, steel, aluminum alloys, copper, zinc, magnesium-based alloys, super alloys and all types of mould and core materials that exist on the market and also exothermic materials as well as chills. Simulations visualize the consequences of a certain design of gating system and moulds. Casting defects such as oxide inclusions due to excessive turbulence, cold-shuts, shrinkage cavities and slag inclusions can be avoided by optimizing the design of the gating and venting system.

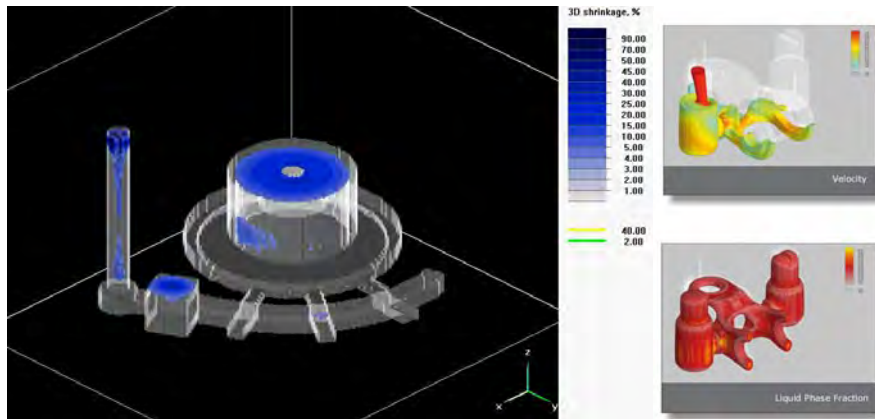

Fig. 1. Print-screen of NovaFlow & Solid interface.

2.2. SIMTEC/Wincast

The program was developed by the company RWP (Germany) and uses the finite difference method (mesh is done automatically). It proposes a complete offer, from filling up efforts to determine the mechanical and thermal model using an elastic or elasto-plastic. In addition to modeling the processes that occur in the gravitational field are dealing with other processes (die casting, low pressure casting, "squeeze casting", "lost foam").



Fig. 2. Screen capture of Simtec interface.

2.3. Metal Master

This program is expected to optimize the composition of cast irons under the conditions obtaining in the development of a minimum cost price, the achievement of numerous tests with various melt compositions: it does not require high performance computers and is very easy to use.

2.4. ProCAST

This program is developed by UES, USA and has a wide range of possible uses, grouped by modules. ProCAST has a way to determine enthalpy and solid fraction depending on temperature and alloy composition. It features a high performance mesh mode. The program integrates: a database of material characteristics, thermal analysis models, the flow and the efforts of components and metallurgical and specific models.

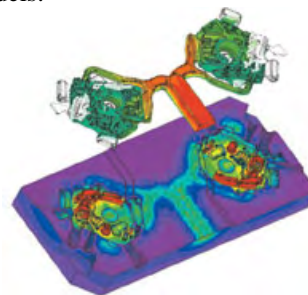

Fig. 3. Low Pressure Casting.

2.5. IronCAD 4.0

It is a package CAD / CAM product company Desing Visionary Systems Inc. - USA and distributed in Romania by Metal Progress Soft. It's designated geometric solids modeling and complex mechanical assemblies, molds, foundry molds, SDV's, electrical installations, and others.



Fig. 4. IronCAD 4.0 program interface.

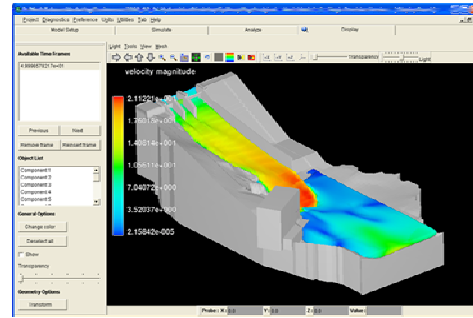

Fig. 5. Simulation flow and filling forms.

2.6. Flow-3D

The program was developed by Flow Science in the U.S. and specializes in the design flow. For application in the foundry to propose a list of models that allow even simulate hydraulic phenomena related to the development of special procedures such as filling the form for the process "lost foam", Thixocoulée".

Resolution is made by the method of control volumes.

2.7. MAGMA

MAGMA is a German program, including flow and solidification, and modular design stays true to revolve around the control volume method. At the same time, the program includes the calculation efforts and deformations. It proposed a method of procedure "thixocoulée", which was developed in collaboration with the EFU. At the same time, models have been developed for determining segregation and mechanical characteristics, based on chemical composition and thermal evolution during solidification.

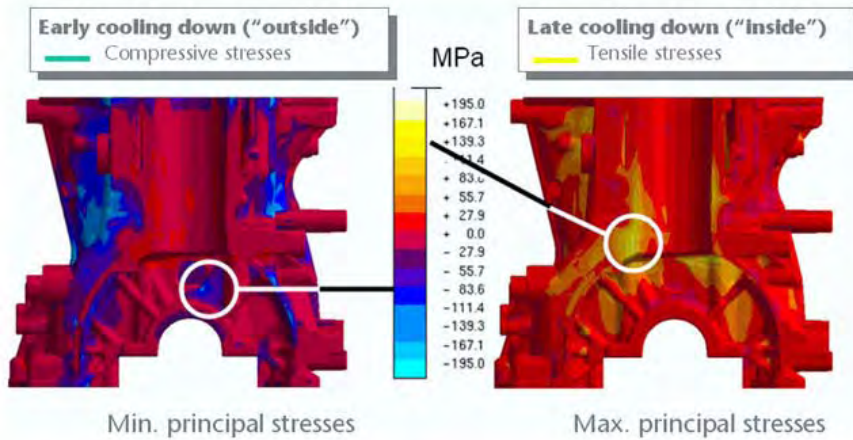

Fig. 6. Magma casting design.

2.8. ATASTM (Adaptive Thermal Analysis System)

It is composed of system control and optimization of design for gray cast iron, malleable and nodular cast iron. The method was developed by NovaCast AB in collaboration with the Swedish Foundry Association and is based on the first derivative of the cooling curve combined with artificial intelligence applied. The system is a fully automatic registration of cooling curve from the time the iron is poured into the sample cup. After registration, the system looks at the curve; it calculate the derivative I and about 40 thermodynamic properties. A test result is usually given in 3-5 min.

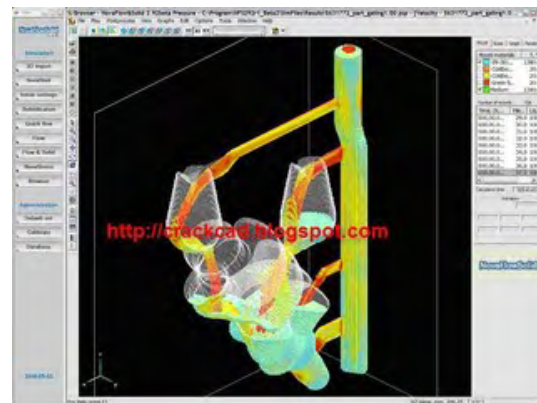

Fig. 7. ATASTM program interface.

2.9. NovaCast

NOVACAST Program (Sweden) presented at the GIFA 1989 Congress solidification of alloys in simulated three-dimensional (3D) has incorporated an interface for downloading directly from AutoCAD drawings cast. The program analyzes the heat transfer finite difference method and can cause iso-solidus

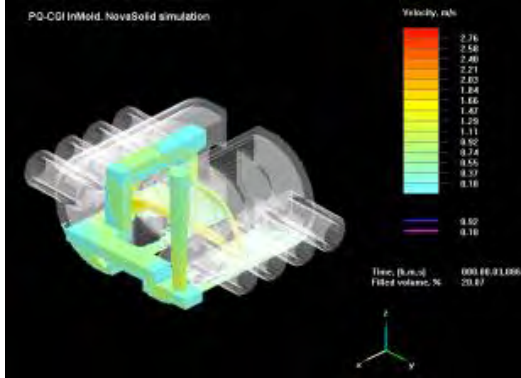

Fig. 8. System Design with NovaCast.

curves, field temperature alloy-form system, the biphasic and the fraction of solidified alloy and place of occurrence and size of areas where appears micro-porosity. Currently, there are two modules: module solidification (NovaSolid) and module simulating cavity filling forms (NovaFlow).

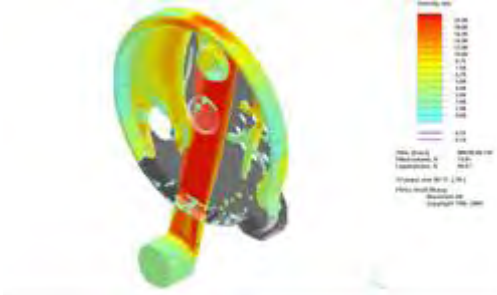

Fig. 9. Modeling and simulation of high pressure die casting.

2.10. CASTech

The program simulates the filling and solidification of castings. Filling in Injection molding, currently proposed to be included in a future version of the program. Program CastDESIGN associated

CastCAE version is used to calculate shrink head, which is to determine their size and location. The choice is made from a database, based on simulation results of solidification processes.

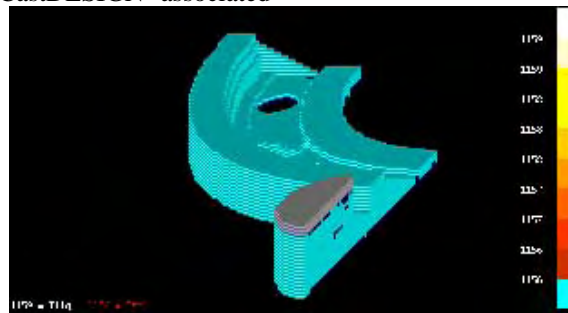

Fig. 10. Porosity simulation with CASTech

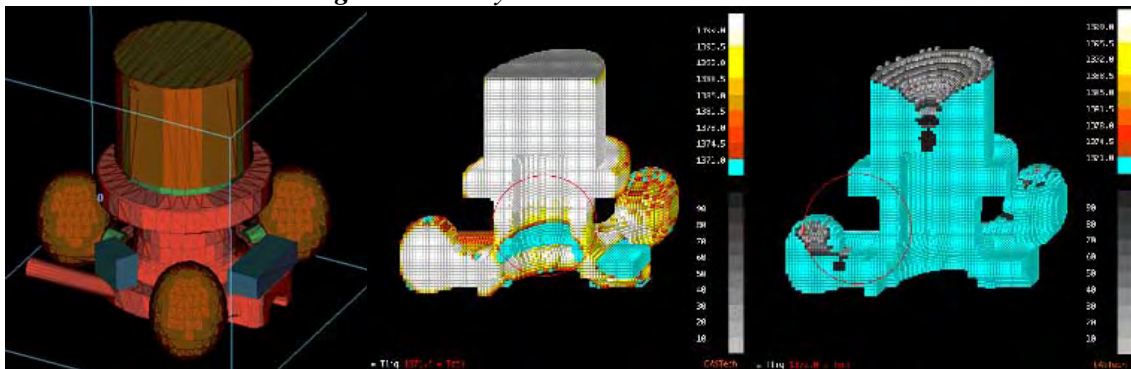

Fig. 11. Modeling of a valve body casting.

2.11. SIMULOR / PAM-CAST

Simulation program developed by Silicon Graphics can simulate flow and solidification of

alloys and is based on finite volume method. The method of calculation used is that of the control volumes. The program offers the following

advantages: the program is modular, allowing computing desired choice; CAO interface programs are taken into account in the thermal model, denser indoor, outdoor and air strips which are formed at the interface alloy-form; it makes a physical database for several aluminum-based alloys.

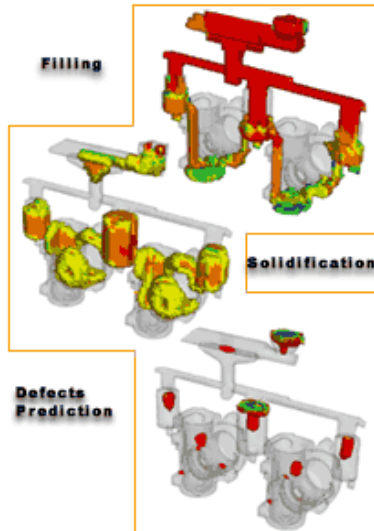

Fig. 12. Specific solvers used at casting process.



Fig. 13. High pressure die casting.

2.12. AFSolid3D

The program is conducted by the American Foundrymen Society and uses the finite difference method and can run on a PC. This program proposed by the foundry in 1986, claimed more than 300 licenses worldwide. It has its own system and enables simulation training CAO shrink hole that occurs during solidification. It is possible, while shaping and filling the cavity, where casting gravitational field.

2.13. SOLSTAR

SOLSTAR company FONSECO program can calculate and divide the piece into a million parts by volume. Thus, multimillion version 3 can be calculated and share a song in 64 million volume elements and multimillion variant 2 than 3 million items in volume. Increased volume elements improve simulation accuracy in case hardening.

The program presents facilities, such as easy to work with files, improved interface, an analysis of areas of developing micro-porosity. The program can be run only on powerful computers.

3. Conclusion

At current technical conditions such a design may be cast to ensure a controlled management of the process of solidification in industrial conditions. The usage of computer to study processes taking place during solidification leads to lower consumption of raw materials and energy, liquid alloy, labor, fluid technology and a significant decrease of time for approval of optimal technology. One of the major problems faced by designers of hardware technology is to achieve the possible removal of its thermal nodes inside castings. Simulation programs made offers to guide the process of solidification so that correctly dimensioning the designer and shrink head exterior or interior, thermal nodes castings should be completely eliminated. The emergence in recent times, the program flow and solidification simulation of composite materials make the new provisions to limit the matrix (metal) and particle or fiber. Phenomena that occur in these conditions are very difficult to simulate because of the multitude of factors that influence the solidification process of composite materials and make mathematical models that describe these processes to be cumbersome and error rising. Generally, the processes of solidification of alloys to be simulated in real conditions with very small errors; making the manufacture of castings has become much easier and it requires less time. This results in a saving of labor, materials and castings lower price, therefore more efficient foundry.

References

- [1]. Godfroid, H. - *Simulation Processes: Computer Simulation and Modeling*, Workshop 50 th Int. Foundry Congress, Cairo, CIATF, 1983.
- [2]. Soporan, V., Vamos, C., Pavai, C. - *Modelarea numerică a solidificării*, Editura Dacia, Cluj – Napoca, 2003.
- [3]. Thomas, B.G. - *Stress and Advanced Solidification Processes VI*, Palm Coast, FL, March 21-26, 1993.
- [4]. Bratu C, Soporan V. - CeEx 260/2006 - *Modelarea matematică a proceselor care au loc la turnarea pieselor metalice, în vederea reducerii consumurilor de materiale și energie*, 2006
- [5]. Cocolas Sorin-Adrian – *Lucrare disertatie – „Model experimental destinat modelarii matematica procesului de curgere la turnarea pieselor”*, 2008.
- [6]. <http://www.castech.fi/>
- [7]. <http://www.ironcad.com/>
- [8]. <http://tptc.iit.edu/Center/Resource/ApplicationOfSoftware/pamcast.html>
- [9]. <http://www.esi-group.com/products/casting/procast>
- [10]. <http://www.novacastfoundry.se/>
- [11]. <http://www.afsinc.org/>