

## STRUCTURE AND CORROSIVE FIRMNESS OF COMPOSITION MATERIALS ON THE BASIS OF COPPER AND MOLYBDENUM GOT METHOD ELEKTRON-BEAM TECHNOLOGY

V.G. GRECHANYUK<sup>1</sup>, V.A. DENISENKO<sup>1</sup>, L.ORAC<sup>2</sup>

<sup>1</sup> Kiev National University of Building and Architecture Ukraine, Kiev,

<sup>2</sup> "Dunarea de Jos" University of Galati

e-mail: [gekont@ukr.net](mailto:gekont@ukr.net)

### ABSTRACT

*The article describe the study of corrosive firmness of composition materials on the basis of copper, obtained by EB-PVD method. Corrosive firmness of condensates was explored by gravimetric method. The especially decreasing of the corrosive stability is definite during concentration of molybdenum about 12 % . Chemical composition of condensates showed that in the stationary terms of receipt of materials, their chemical composition is heterogeneous on a thickness. The structure of condensate has the expressly expressed macro-laminated character, the size of layers hesitates from a few ten microns of the to several hundred.*

KEYWORDS: composite materials, EB-PVD, corrosive stability.

### 1. Introduction

Lately wide application for making of electric contacts was found by the condensed from a steam phase composition materials Cu-Mo-Zr-Y.

The indicated materials with concentration of molybdenum to 12 % mass. are used in the contacts of alternating and permanent currents by force to 1000 A. Attempts to get similar materials with greater concentration of molybdenum on revolved at a speed of 38 turns in a minute on substrate at the temperature of besieging  $700 \pm 30$  °C success was not had.

In such condensates there was friable destruction in the process of deposition.

In also time the receipt of the condensed materials is of interest on the basis of copper and molybdenum with greater concentration of molybdenum and expansion of possibilities of application of these compositions in the range of currents over 1000A.

### 2. Experimental

The composition materials Cu-Mo were got on stationary substrate made from carbon steel, measuring 250x220x10 mm at the temperature  $900 \pm 30$ °C method of electron-beam evaporation and subsequent condensation in a vacuum on a technological scheme, presented on the fig. 1.

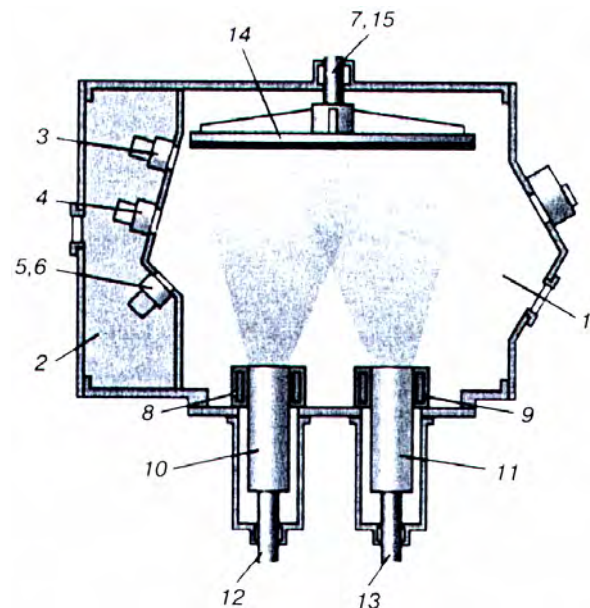

**Fig. 1.** Scheme of receipt of the composition materials Cu-Mo: 1 – working chamber; 2 – gun chamber; 3 - 6 – EB heaters; 7 – substrate rotation rod; 8, 9 – crucibles for evaporation of copper and molybdenum, respectively; 10, 11 – ingots for evaporation; 12, 13 – mechanisms for feeding ingots into evaporation zone; 14 – disc-substrate; 15 – substrate rotation mechanism.

The presented technological scheme allowed to form the condensed compositions with a gradient for concentrations of molybdenum from 0 to 32.5% mass. (basis copper).

The study of chemical composition of condensates showed that in the stationary terms of receipt of materials, their chemical composition is heterogeneous on a thickness (fig.2).

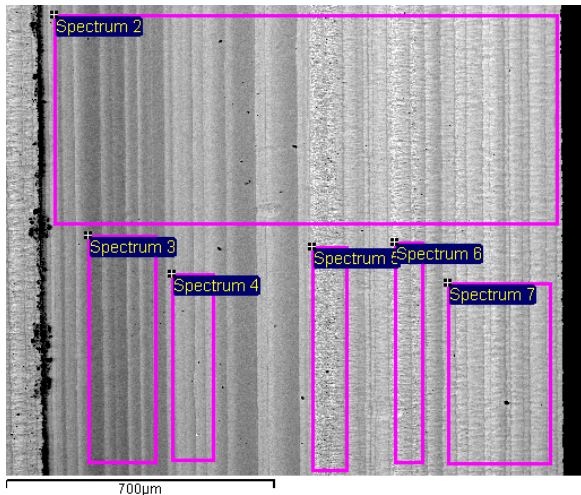

Spectrum	Cu	Mo	Total
Spectrum 2	87,57	12,43	100
Spectrum 3	96,19	3,81	100
Spectrum 4	86,96	13,04	100
Spectrum 5	79,76	20,24	100
Spectrum 6	81,82	18,18	100
Spectrum 7	84,02	15,98	100

*Fig.2. Chemical composition on the thickness of condensate*

Neutralized chemical composition on the thickness of condensate shows concentration of molybdenum 12.43% mass. In also time, distribution of components on separate areas on the thickness of

condensate has a heterogeneous character and hesitates from 3.81 to 20.24 % mass. The data resulted on fig.3 testify to heterogeneity of distributing of components.

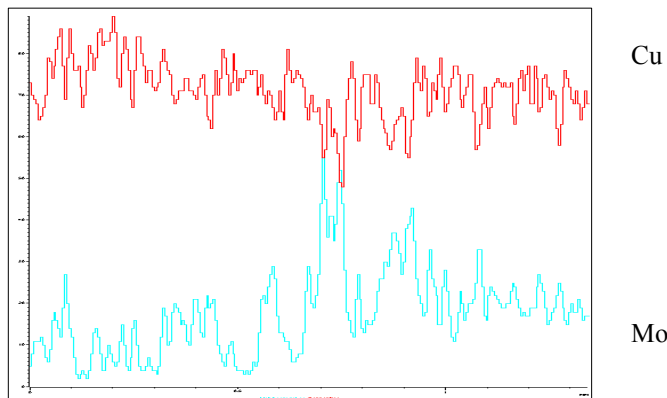

*Fig. 3. Distribution of components on the thickness of condensate*

### 3. Results and discussions

The analysis of distributing of components in area of minimum maintenance of molybdenum shows that there is heterogeneity on a molybdenum even in a relatively narrow region, so on a depth a 50 µm heterogeneity hesitates from 0.11 to 3.89 % mass. Molybdenum.

The structure of condensate has the expressly expressed macro-laminated character. The size of layers hesitates from a few ten microns of the to

several hundred. Interface of macro-layers clear without the visible distortion conditioned by the roughness of substrate (fig.2). In also time of micro-lamination, discovered before in the condensed materials got on revolved substrate, is not exposed.

Increase of concentration of molybdenum on the neutralized chemical analysis from 12.43 to 40.36 % mass. direct substantial change of macrostructure of condensate (fig.4).

Interface between macro-layers has a wavy character.

The level of heterogeneity of distribution of molybdenum and copper in macro-layers is increased.

The character of distribution of components is presented on the fig. 5.

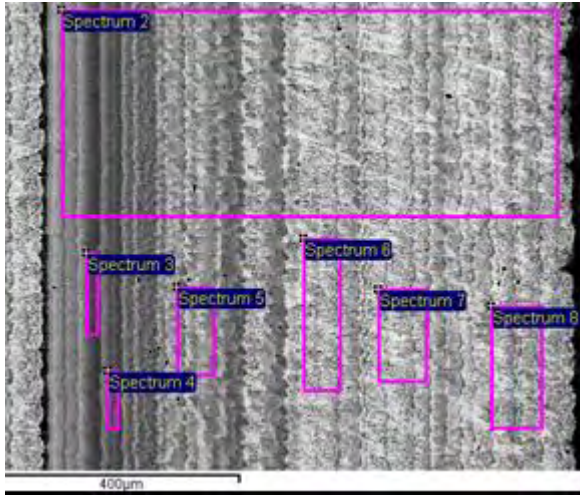

**Fig.4.** Structure of condensate with the raised content of molybdenum

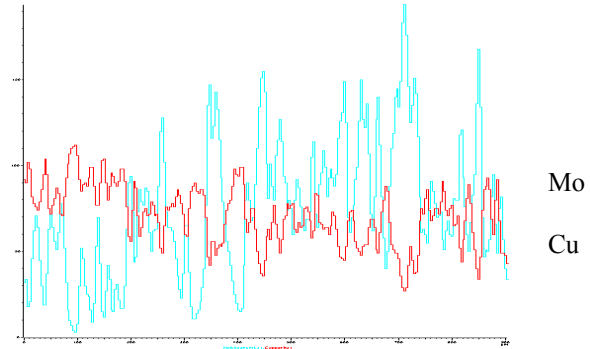

**Fig.5.** Distribution of components on the thickness of condensate

For regions with the maximal content Mo (fig.6) the unclear expressed columnar with predominating content of molybdenum (the light field) and promoted concentration of copper (the dark field).

composition of corrosive environment before and after conducting of corrosive tests, and also electronic-microscopic researches.

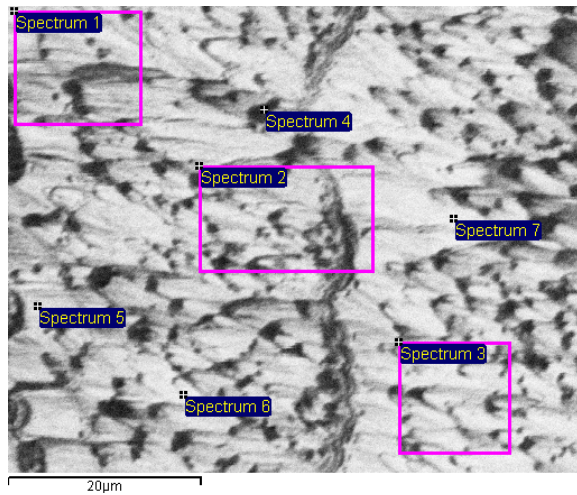

**Fig.6.** Distribution of components in a region with maximum content of molybdenum

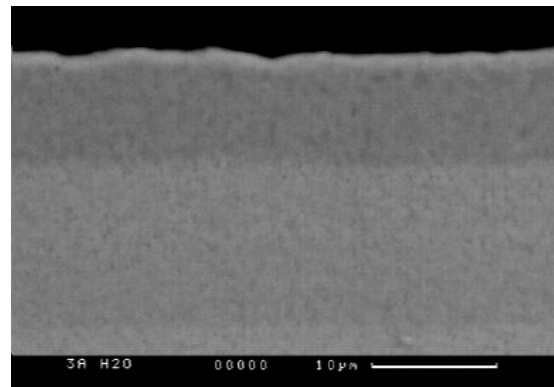

**a.**

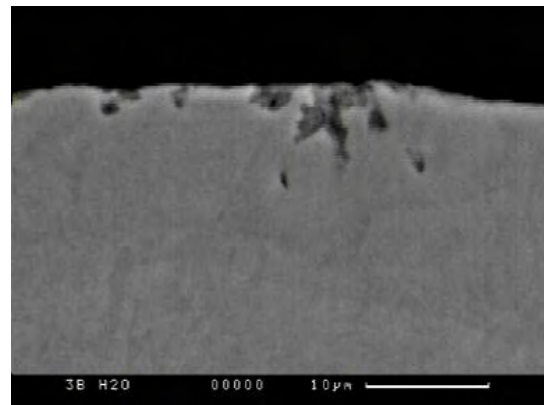

**b.**

Corrosive firmness of condensates was explored by gravimetric method. Samples by an area 100 mm<sup>2</sup> after preliminary treatment placed on corrosive agent (water) on 100 hours. The control after the change of mass of samples was carried out in every 20 hours. Researches were conducted in the static mode in the distilled water. Gravimetric researches complemented by determination of

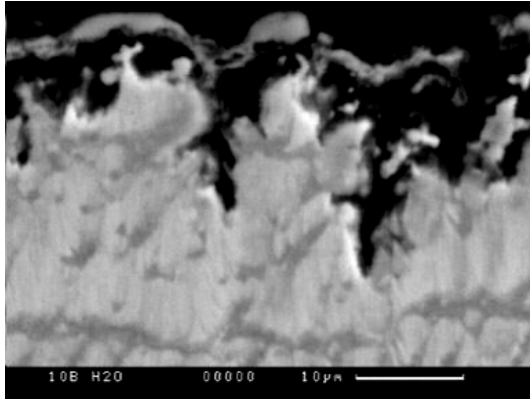

c.

*Fig.7. The electronic-microscopic researches of condensate after the corrosive testing*

The electronic-microscopic researches of condensate, conducted after the corrosive testing, showed that at small concentrations of molybdenum destruction of surface of samples is practically absent (fig.7, a), and is observed only on areas, on which are present the defects of structure (fig.7 b, c), caused by a technological process.

At the increase of concentration of molybdenum destruction of surface is increased and on separate areas can achieve at 20 μm (fig.7, c).

#### 4. Conclusions

1. The rise of temperature of substrate with 700 °C to 900 °C during joint condensation of copper and molybdenum on stationary substrate allows to get the condensed material on the basis of copper and molybdenum with the promoted content of molybdenum.
2. For condensates of got in stationary terms the macro-layers with chaotic their distribution on the thickness are characteristic.
3. Corrosive destructions are observed on areas on which are present defects of structure.

#### References

- [1]. M.I. Grechanyuk, V.O. Osokin, I.B. Afanasiev, I.M. Grechanyuk - *Pat. 34875* Ukraina. MPK C23C/20. Compozitionnai material dlia electriceskih contactov i sposob ih proizvodstva, Opubl. 30.12.2002; Bul. Nr.12.
- [2]. N.I. Grechanyuk, V.A. Osokin, I.B. Afanasiev, I.N. Grechanyuk - *Electronno-lucevaia tehnologhia polucenia materialov dlia electriceskih contactov*, Electriceskie contacta i electrode: Sb. Tr. – Kiev: IMP NANU, 1998. – S. 51-66.
- [3]. *TU U 201/3410.001-98*. Materiala dispersno-uprocinennae dlia electriceskih contactov. – Vved. 01.05.98.
- [4]. B.A. Movcian, V.A. Osokin, L.V. Pusecnicova, N.I. Grechanyuk - *Electronno-lucevoe isparenje i condensatia medi cerez vannu-posrednic*, Probl. spet. electrometallurghii. – 1991. – Nr. 3 – S. 58-61.
- [5]. Nesmeianov A.N.- *Davlenie para himiceskih elementov*. – M.: Izd-vo AN SSSR, 1961. – 396 s.