

SURFACE TENSION OF LIQUID COPPER IN DILUTE OXYGEN CONCENTRATIONS

Maria VLAD, Elisabeta VASILESCU

"Dunărea de Jos" University of Galati

e-mail: mvlad@ugal.ro

ABSTRACT

The studies of this paper regarding the influence of low oxygen contents on the liquid copper surface tension had as base „sessile drop” method and the determination of the oxygen content using calculation ratio where partial pressure of the oxygen is in equilibrium with the melt in a gaseous atmosphere. The surface tension of the liquid copper, with very low oxygen contents has been studied at various temperatures (1373, 1423, 1473, 1523 and 1573 K).

KEYWORDS: superficial tension, copper, oxygen content

1. Introduction

The „sessile drop” method makes the size analysis of a drop resting on a horizontal and flat support, figure.1. The drop is considered in equilibrium under the action of the capillary forces and its weight.

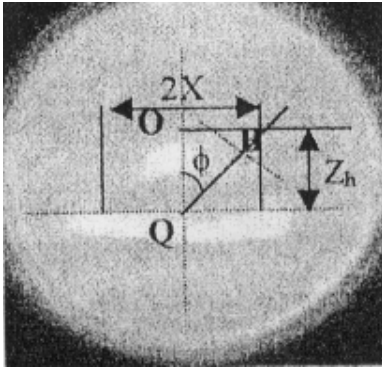

Fig. 1. Geometry of a drop rested on an inactive support.

The pressure, P, of the liquid in a point B is given by the relation:

$$P = \sigma \left(\frac{1}{R_1} - \frac{1}{R_2} \right) = \rho g z + c \quad (1)$$

where: z – is the vertical distance of point B from the axis origin,

g – is gravity acceleration,

ρ - is density difference between liquid and environment,

R_1 and R_2 curvature radius of the point B considered by interface of a tow normal planes, c – is a constant.

If X is the abscissa of the point B considered at interface and φ - is the angle made by the normal to the surface in this point and by the vertical axis, one of the curvature is $R_1 = X / \sin \varphi$, and the other one is $R_2 = R$.

Consequently:

$$\sigma \left(\frac{1}{R} + \frac{\sin \varphi}{X} \right) = \rho g z + c \quad (2)$$

Studying the condition of the limit, $y=0$, $R_1=R_2=b$, where b is curvature radius at drop top, it is concluded $c=2 \sigma / b$. Relation (2) may be as following:

$$\frac{b}{R} + \frac{b \sin \varphi}{X} = 2 + \frac{\rho g b^2}{\sigma} \cdot \frac{z}{b} = 2 + \beta \frac{z}{b} \quad (3)$$

The drop shape is depending on the parameter $\beta = \rho g b^2 / \sigma = b^2 / a^2$, where β is named shape factor and a^2 capillary constant. Using the numerical calculation proposed by Bashforth and Adams, the analyses of the drop profile allows determination of value a^2 and, consequently, of a superficial tension:

$$\sigma = \frac{b^2}{\beta} g \rho = z^2 g \rho \quad (4)$$

Drop parameters required for surface tension determination are determined by taking a photo of the apparatus belonging to the outfit used for determination. Also, photos have access to the measurement of the joining angle θ of the liquid on the support. Generally, the measured parameters are

the equatorial diameter $2R$, the distance z from drop top to equatorial plane, or the distance h from point O to point A. The precise position of this plane is not easy to be determined because it is not a symmetry plane.

2. Materials and equipment

The experimental determination was made at Miskolc University on an installation, schematically represented in figure.2.

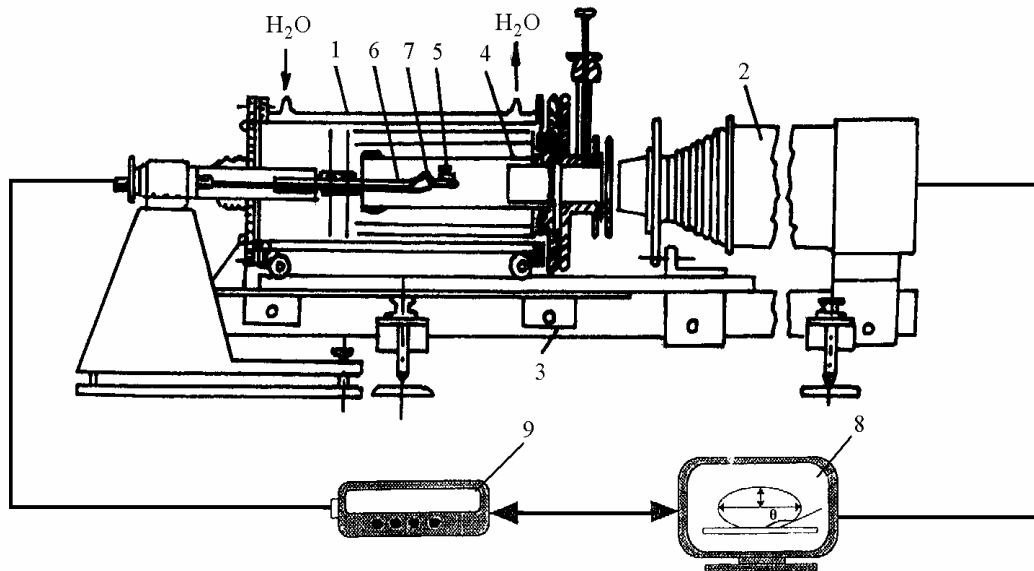

Fig. 2. Schematic arrangement of the experimental apparatus.

- | | |
|---|---|
| 1. furnace cooler; | 6. thermocouple |
| 2. camera CCD and microscope objective | 7. Al ₂ O ₃ support |
| 3. support | 8. image of the metal drop |
| 4. Al ₂ O ₃ protective tube | 9. digital multimeter |
| 5. alloy drop; | |

Heating and test specimen melting were made by a horizontal electrical resistance furnace with a silicon carbide heating element. In the furnace is a zone of uniform temperature along side of 4 cm where temperature variation is ± 1 K and a zone of 8 cm length where temperature variation is ± 5 K at 1723 K. Drop temperature was measured by a thermocouple Pt-PtRh 13 placed under the purity recrystallized Al₂O₃ disk, used as support of the drop. Disk surface was polished with corundum powder and well washed, in advance, in alcohol and acid solution, distilled water and acetone, and heat up in vacuum at about 1700 K afterwards. The photos of the molten hot drop were made by a 35 mm camera with fix focusing combined using 5 or 10 mm diameter steel balls.

3. Experimental procedure

The copper used as test specimen having 99,99% purity was vacuum remelted. To check the molten copper drop condition and measure surface tension in pure hydrogen atmosphere, when

$P_{O_2} < 10^{-20}$ atm. same photo have been taken. After introduction of H₂ – CO₂ mixture it was found that molten copper drop reached in equilibrium with this gas after about 2 hours from mixed gas admission. The measurements of the superficial tension were made after still maintaining the equilibrium state for another hour. The partial pressures of the oxygen in equilibrium with H₂ – CO₂ mixtures were determined at high temperature, considering the gaseous mixture as H₂, CO₂, H₂O and CO attending to the reaction:



The equilibrium constant K of the reaction (5) is given by the relation:

$$k = \frac{P_{H_2O} \cdot P_{CO}}{P_{H_2} \cdot P_{CO_2}} \quad (6)$$

Between the partial pressures of the gases H₂O(v), CO, H₂ and CO₂ the following relation could be written.

$$\frac{(P_{CO_2})_i}{(P_{H_2})_i} = \frac{P_{CO_2} + P_{CO}}{P_{H_2O} + P_{H_2}} \quad (7)$$

where coefficient „i” is referring to the initial gaseous mixture. Considering $P_{H_2O} = P_{CO}$ and replacing equation (6) into (7) results in:

$$\frac{(P_{CO_2})_i}{(P_{H_2})_i} = \frac{P_{CO_2}(1 + P_{CO_2}/P_{CO})}{P_{CO}(1/k + P_{CO_2}/P_{CO})} \quad (8)$$

$$P_{O_2} = \frac{1}{4} k_1^2 \left[\frac{(P_{CO_2})_i}{(P_{H_2})_i} - 1 + \sqrt{\left\{ \frac{(P_{CO_2})_i}{(P_{H_2})_i} - 1 \right\} + \frac{4(P_{CO_2})_i}{k(P_{H_2})_i}} \right]^2 \quad (11)$$

As k and k_1 are known for a given temperature the equilibrium partial pressures of the mixture's oxygen has been calculated from the equation (11) for a given ratio $(P_{CO})_i / (P_{H_2})_i$ of the initial mixture. Finding the partial pressure of the oxygen in gaseous phase by the above mentioned relations, the dissolved oxygen content in molten copper could be calculated supposing that CO-CO₂ mixture is in equilibrium with the melt.

The chemical reaction was considered:

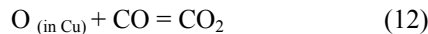

$$a_o = \frac{1}{2k_2} \left[\frac{(P_{CO_2})_i}{(P_{H_2})_i} - 1 - \sqrt{\left\{ \frac{(P_{CO_2})_i}{(P_{H_2})_i} - 1 \right\} + \frac{4(P_{CO_2})_i}{k(P_{H_2})_i}} \right] \quad (15)$$

At very low concentration of oxygen $a_o = [\%O]$ so that $[\%O]$ could be calculated with equation (15).

4. Experimental results

The experimental results of the surface tension variation function of copper temperature at low quantities of oxygen are given in table 1.

Considering the chemical reaction:



$$k_1 = \frac{P_{CO} \cdot P_{O_2}^{1/2}}{P_{CO_2}} \quad (10)$$

So that the following expression is obtained from equation (8) and (10)

$$k_2 = \frac{P_{CO_2}}{P_{CO} \cdot a_o} \quad (13)$$

where a_o is the oxygen activity in the molten copper.

The temperature dependency of k_2 constant is given by Sake as following:

$$\log k_2 = \frac{10600}{T} - 3.82 \quad (14)$$

Replacing equation (10) in equation (13) the oxygen activity in molten copper, a_o , was determined from relation:

The surface tension variation on liquid copper with 0.012% oxygen; versus temperature and $\log P_{O_2}$ is given in table 2.

Table 1. The surface tension variation of copper with low oxygen contents at different temperatures

Number	0,005 % oxygen		0,012 % oxygen		0,068 % oxygen	
	T[K]	σ [mN/m]	T[K]	σ [mN/m]	T[K]	σ [mN/m]
1	1373	1296	1373	1186	1373	915
2	1423	1293	1423	1194	1423	943
3	1473	1291	1473	1208	1473	965
4	1523	1290	1523	1216	1523	980
5	1573	1276	1573	1225	1573	996

Table 2. The surface tension variation on liquid copper with 0.012% oxygen; versus temperature and $\log P_{O_2}$

Number	1373 K		1473 K		1573 K	
	$\log P_{O_2}$ [atm]	σ [mN/m]	$\log P_{O_2}$ [atm]	σ [mN/m]	$\log P_{O_2}$ [atm]	σ [mN/m]
1	-11.52	1298	-11.21	1292	-11.02	1288
2	-10.05	1279	-9.93	1281	-9.90	1285
3	-8.82	1225	-8.73	1229	-8.75	1238
4	-8.20	1188	-8.11	1210	-8.10	1227
5	-7.60	1138	-7.10	1161	-7.20	1180
6	-6.52	917	-6.31	967	-6.45	998

Relation between the surface tension (σ) of liquid copper with 0.005% oxygen at different temperatures and $\log P_{O_2}$ is given in fig.3

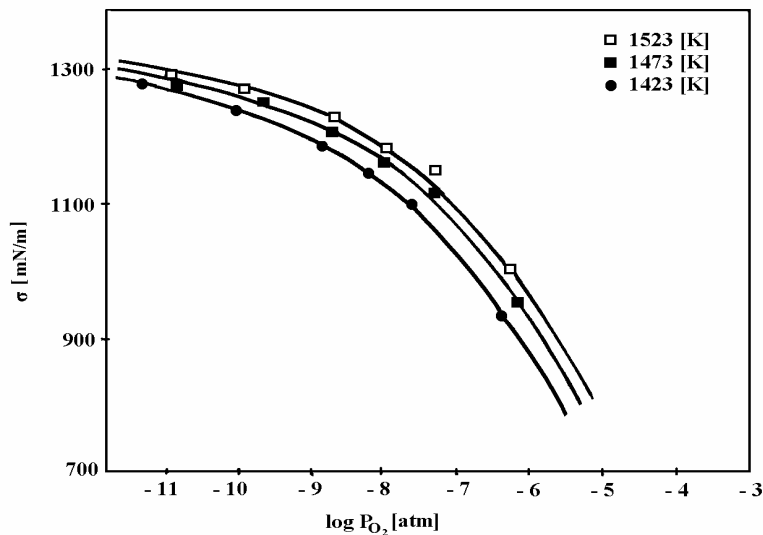

Fig. 3. Relation between the surface tension (σ) of liquid copper with 0.068% oxygen at different temperatures and $\log P_{O_2}$

5. Conclusions

1. The determination of the oxygen content was made by using calculation ratio where partial pressure of the oxygen is in equilibrium with the melt in a gaseous atmosphere.

2. The experimental results show that at 0.005% oxygen the influence of oxygen on surface tension of liquid copper is very small

3. For a little bit higher oxygen concentration in copper (0,012 % oxygen and 0,068 % oxygen) could be noted a light increase of the surface tension on temperature increase.

References

- [1]. Taihei Matsumoto, Hidetoshi Fujii, Takaharu Ueda, Masayoshi Kamai and Kiyoshi Nogi, *Measurement of surface tension of molten copper using the free-fall oscillating drop method*, Meas. Sci. Technol. 16, p. 432-437, 2005
- [2]. Zhangfu Yuan, Jianfeng Fan, Jing Li, Jiajun Ke and Kusuhiro Mukai, *Surface tension of molten bismuth at different oxygen partial pressure with the sessile drop method*, Scandanavian Journal of Metallurgy Volume 33, p. 338 December 2004.
- [3]. P. Sahoo, T. Debroy, and Mc.Nallan N.J., *Metal Transaction B.*, vol.19B, 1988, p.483-490.
- [4]. Keene B.J - *International Materials Reviews*, vol.38, nr.4, 199
- [5]. M.Vlad, Thesis of doctor, *Researches on microalloying copper base alloys*, "Dunarea de Jos" University, Galati, 1994, Romania.