

DETERMINING THE STRESS-STRAIN CURVE OF PDMS-SiO₂-TiO₂ ELECTROACTIVE POLYMERS

Vlad CÂRLESCU¹⁾, Dumitru OLARU¹⁾, Gheorghe PRISĂCARU¹⁾, Stelian VLAD²⁾

¹⁾The “Gheorghe Asachi” Technical University of Iași, Machine Elements, Mechatronics and Robotics Department, Iași, ROMANIA

²⁾”Petru Poni” Institute of Macromolecular Chemistry, Iași, ROMANIA

carlescu.vlad@yahoo.com, vladus@icmpp.ro

ABSTRACT

The aim of this paper is to investigate the mechanical properties of PDMS-SiO₂-TiO₂ electroactive polymers. Recently, the electroactive polymers are emerging as possible candidates for actuators and sensors applications at micro and nano scales. Generally, the characteristics like large strain, high stress, high energy density, good efficiency and high response speed are required to obtain a good overall actuator performance. The mechanical tensile tests were performed on elastomer specimens using a tensile test machine from TIRA, Germany. The stress-strain measurements were made on dumbbell shaped cut form thin films, at an extension rate of 50 mm/min, at room temperature. The preliminary results showed an elastic modulus ranging from 0.1 MPa to almost 1 MPa. We concluded that the tested elastomers are suitable for the electroactive polymer actuators, for example, as microactuation systems in MEMS technology.

Keywords: Electroactive polymers, silicone elastomer, actuators, tensile test

1. INTRODUCTION

Research on the polymer based actuators is a relative young field of interest. It dates back to the early work by Kuhn and Katchalsky [1], in the fiftieth, but the progress has especially been obtained from 1980 till today.

The electroactive polymers (EAPs) materials are an alternative to the materials commonly used for actuators and sensors, e.g. the piezoelectric ceramics, the shape memory alloy, the magnetostrictive materials and the electrorheological fluids.

EAPs are materials that produce the significant shape and size change in response to the electrical stimulation (current or voltage).

In order to transform these materials from the developing phase to an application as effective actuators, there is a need for an established infrastructure. For this purpose, the

efforts are underway to develop a comprehensive understanding of EAP materials behavior, as well as the effective processing, the shaping and characterization techniques.

Having the actuation capability in addition to the other advantages of the polymers, including lightweight, low cost and fracture tolerance, all make these materials highly attractive.

These materials can be used to make the mechanical devices and the robots with no traditional components like gears and bearings, which are responsible to their high costs, weight and premature failures [2].

Th electroactive polymers can be divided into two major categories based on their activation mechanism, including ionic and electronic.

The electronic EAP are driven by Coulomb forces and they include: dielectric EAP, electrostrictive graft elastomers, electrostrictive paper, electro-viscoelastic elastomers, ferroelectric polymers and liquid crystal elastomers (LCE).

This type of EAP materials can be made to hold the induced displacement while activated under a high DC voltage, have a great mechanical energy density and they can be operated in air with no major constraints, allowing them to be considered for the robotic applications.

In contrast to the electronic EAP, the ionic EAP are materials that involve the mobility or the diffusion of the ions and they consist of two electrodes and an electrolyte.

The activation of the ionic EAP can be made by as low as 1–2 V and mostly a bending displacement is induced. The ionic EAP include carbon nanotubes (CNT), conductive polymers (CP), electrorheological fluids (ERF), ionic polymer gels (IPG) and ionic polymer metallic composite (IPMC).

The induced displacement of both the electronic and ionic EAP materials can be designed geometrically to bend, stretch or contract [2].

Recently, much attention has been paid to the soft elastomers, mostly silicone [3-7] and acrylic elastomers [7-12], as dielectric electroactive polymers (DEAPs), in the field of novel actuator technology.

VHBTM acrylic elastomers from 3M have been widely used in the actuators and have shown good performance by producing large strains [7-9,11,12]. However, in contrast to the acrylic elastomers, the silicones have the possible advantages of a high stability over a wide temperature range, a fast response speed and a high efficiency [13, 14]. For this reason, there is a growing interest in developing new silicone elastomers as dielectric materials.

Recently, Michel et al. [15] realized a quantitative comparison between a new Dow Corning silicone (DC 3481) and two versions of a VHBTM acrylic elastomer film from 3M: VHB4910 and VHB F-9473PC. They determined the passive material properties in four different tests (uniaxial tensile test at various temperatures, uniaxial stress relaxation test at ambient temperature, uniaxial cyclic strain test at ambient temperature and torsional dynamic mechanical thermal analysis - DMTA) and the active behavior in the electromechanical tests. They concluded that the elasticity of silicone DC 3481 is approximately 0.4 MPa and almost temperature independent in the range of -25°C to 150°C. It has low viscosity and fast electromechanical response time (3 s). In contrast, the acrylic elastomer shows a strong temperature dependence of the elastic modulus and the actuators made from this material should be operated in a controlled ambient environment. It has a long electromechanical response time and high viscosity.

In this paper, we performed only uniaxial tensile tests on PDMS-SiO₂-TiO₂ silicone elastomers to obtain the stress-strain curve and to calculate the Young modulus. All tests were made at room temperature.

2. EXPERIMENTAL

2.1. *Materials and Specimen Preparation*

Polydimethylsiloxane (PDMS) is chemically inert, thermally stable, permeable to gases, simple to handle and manipulate, has a low Young's modulus, low cost, exhibits isotropic and homogeneous properties, is transparent, non-fluorescent, biocompatible and nontoxic.

Due to the interesting properties, PDMS play a structural role in MEMS, serving as protective layers, encapsulates, valve diaphragms, micropumps, fluidic channel structures, etc. Also, it has been used for developing modulable optical systems and as a biomaterial in catheters, drainage tubing, insulation for pacemakers, membrane oxygenators, ear and nose implants [16], bio-compatible substrate for cell behavior studies [17,18].

The incorporation of the different inorganic components into siloxane-based structures is carried out in order to improve the mechanical, thermal, electrical and optical properties [19-21]. Silica, in the form of silica fume or aerogel with the particle sizes in the nanometric range is the most preferred filler for silicones, although carbon black has been also used [22]. Other components can be added, as well as to achieve the desired properties. Thus, the ferric oxide, the titanium dioxide and the organometallic compounds are added as heat stabilizers or pigments [23].

The titanium dioxide is one of the most important fillers used for obtaining the composites designed for engineering applications [24]. Titania has a high dielectric constant ($\epsilon \sim 89$), being of real interest as an active filler in the modification of the dielectric properties of silicones, as well as of other polymers [25, 26].

The materials were provided by Petru Poni Institute of Macromolecular Chemistry (Iasi, Romania).

The composites based on polydimethylsiloxane incorporating silica and titania were prepared, using a solvent-free sol-gel procedure. The chemical, dielectric and nano-actuation properties of prepared composite films were investigated. More detailed information about the preparation and the characterization of PDMS-silica-titania composites can be found in [27, 28].

For determining the passive mechanical behavior, the thickness was of 0.6–0.75 mm (comparable to the thickness of widely used VHB4910 and VHB4905 acrylic elastomers). The thickness was measured with a digital micrometer. All samples were measured three times and the averages were obtained.

2.2. *Equipment and Test Method*

While standard tests are available for the quantitative determination of the passive behavior, the active behavior (electromechanical response) of the dielectric elastomers is also necessary to be investigate using methods introduced in Pelrine et al. [7]. Due to the fact that modelling the dielectric elastomers and especially the electromechanical coupling, is still an open issue in research, the appropriate testing methods are needed, which can be used to experimentally determine the material properties. Up to now, no standard test procedure has been established for this purpose.

Thus, for determining the passive properties of materials, different mechanical tests must be made, such as the uniaxial tension test at various temperatures, the uniaxial stress relaxation test, the uniaxial cyclic strain test and the torsional dynamic mechanical analysis (DMTA), the creep tests.

In our work, the uniaxial tensile tests were performed on dumbbell shaped cut from thin films on a TIRA test 2161 apparatus, Maschinenbau GmbH Ravenstein, Germany. The

measurements were run at an extension rate of 50 mm/min, at room temperature. The stress versus strain behavior was measured. To perform the measurements, the elastomer samples were cut using a hand operated cutting press (Fig. 1).

The Hand Operated Test Sample Cutting Press has been specifically designed to cut shapes, such as the test samples from relatively flexible materials, such as plastics, fabrics, boards and paper. In most cases, the thickness of the material that can be cut, will not just depend on the strength of the material, but also on the lateral flexibility of the material to allow the cutter to penetrate down into and pass through the material. In other words, if the material is too rigid, the thickness of the material that can be cut will be reduced because the outside edges of the cutter blades will bind in the material and therefore reduce the available cutting force. The press generates on average up to 600 kg (6 KN) of cutting force (depending on the strength of the operator).

A schematic view of the specimen is illustrated in Figure 2. The dimensions of specimens are listed in Table 1.

The specimens were fixed at upper and bottom ends using two clamps equipped with manual clamping flat jaws. The force sensor (100 N) is placed on the upper end of the specimen, and the traction was applied at the bottom end. The tensile tests were performed until the specimen is broken.



Fig. 1. Hand Cutting press

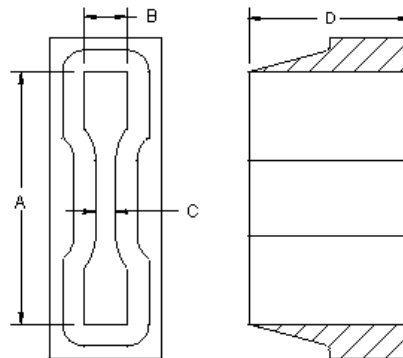

Fig. 2. Schematic of the specimen

Table 1. Dimensions of the specimen

Specimen	Nominal dimension [mm]
A	50
B	8.5
C	4
D	31.75

3. RESULTS

The uniaxial tensile tests were performed on the dumbbell shaped cut from the thin films at an extension rate of 50 mm/min in room conditions.

The tensile test machine recorded the tensile force and the elongation of the specimen during the tests. Figure 3 gives an example of the tensile force-elongation diagram.

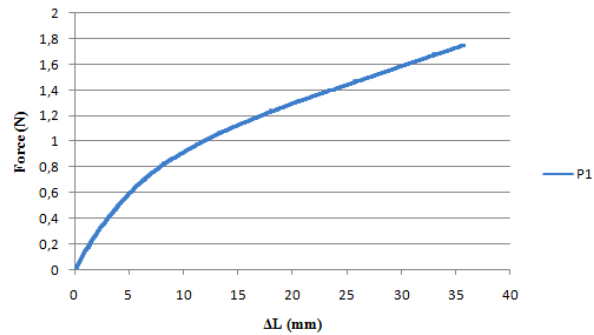

Fig. 3. Force versus elongation at 50 mm/min

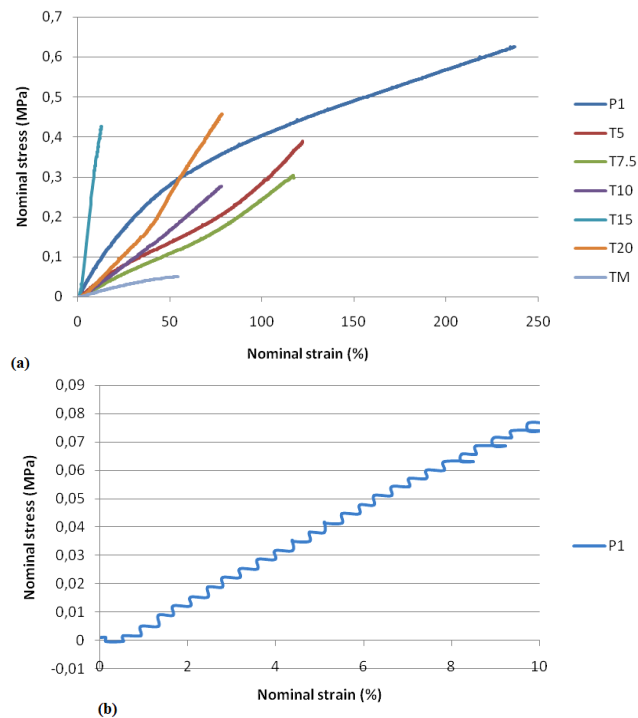

Fig. 4. Stress versus strain curves at room temperature: (a) full elastic regime; (b) low-strain regime

The stress-strain curves of all specimens are shown in Fig. 4a, while the more important range from 0 to 10% is magnified in Fig. 4b.

We calculate the tangent modulus called Young's modulus, from the initial linear portion of stress-strain curve as the slope of curve.

In table 2 are listed the parameters obtained from tensile tests.

Table 2. Tensile tests results

Sample	Young's modulus (MPa)	Tensile strength (MPa)	Elongation (%)
P1	0.8	0.625	237.26
TM	0.11	0.0432	54.44
T5	0.34	0.388	122.281
T7.5	0.21	0.303	117.57
T10	0.26	0.277	78.11
T15	0.35	0.4616	83.06
T20	0.34	0.4575	78.44

4. DISCUSSION

From the stress-strain curves (Fig. 3a), it can be concluded that all specimens have a non-linear elastic response of a classic neo-Hookean solid.

In particular, the sample P1 shows a large strain range of up to 237%, about half of the strain range produced by VHB 4910 acrylic [15] and Nusil R-2631 (Shore A40) silicone [29] and an elongation of approximately 35 mm at 1.8 N. Both stress-strain curves, of P1 and VHB 4910, have a similar trend. However, VHB 4910 and Nusil R-2631 have a higher strain range of up to 500%.

The other samples showed modest elongations, comparable to those of Dow Corning silicone (DC 3481) [15].

The tensile strengths of the specimens are ranging from 0.0432 MPa to 0.625 MPa. TM specimen has the lowest elongation and tensile strength of 54.44% and 0.0432, respectively.

The values of Young's modulus calculated here are in agreement with those reported by Michel et al. [15] for DC 3481 and Scoot et al. [30] for PDMS (Dow Sylgard 186). The comparison can be generally made, as the used here silicone-based elastomers differ in composition with those from references [15] and [30].

Therefore, the PDMS-SiO₂-TiO₂ composite films investigated in this paper are interesting candidates as dielectric materials in the electroactive polymer actuators.

Due to the fact that the viscoelastic properties play an important role in the elastomer materials, the additional measurements at various temperatures are needed in order to assess the thermal stability.

The viscosity of the materials is an inherent reason of the mechanical losses (the dissipated work) during the actuation. For high-efficiency actuators, the materials should have low mechanical losses, a situation that is usually dependent on the activation frequency.

To investigate the dissipated work of the silicone and acrylic elastomers, the uniaxial cyclic strain tests are needed. Another important parameter that quantifies the dissipation energy is the phase shift (δ) between the stress and the strain versus time function.

We reported electromechanical measurements on PDMS-SiO₂-TiO₂ composite film sandwich between rigid plate electrodes [31]. The thickness contractions were investigated at high DC voltage steps.

Frequency dependence of strain under high sinusoidal voltages was investigated on rectangular samples coated with aluminum foils. Vibration modes of electroactive polymer films were carried out using a non-destructive test method [32].

Finally, more mechanical and electromechanical tests are needed for a complete characterization of PDMS-SiO₂-TiO₂ elastomers, either in planar and circular configurations.

5. CONCLUSIONS

The ensile tests were performed on PDMS-SiO₂-TiO₂ elastomer films for the purpose of using them as dielectric layers in EAP actuators. The tensile tests were made on dumbbell shaped cut from thin films with a thickness ranging from 0.6 mm to 0.75 mm, at an extension rate of 50 mm/min. The Young's modulus was determined from the slope of the initial linear portion of the strain-stress curves and it found to be in range of 0.1-0.8 MPa. The specimen P1 showed the largest strain range (237%) and the lowest tensile strength (0.625 MPa).

The results obtained in this work are in agreement with those in literature and allow us to propose these materials, especially P1 specimen, to be used in the electroactive polymers actuators at micro and nano-scales.

We tend to continue characterizing more silicone-based elastomers to find interesting materials needed in EAP technology.

REFERENCES

1. Kuhn W.; Hargitay B.; Katchalsky A.; Eisenberg H., 1950, Reversible dilation and contraction by changing the state of ionization of high-polymer acid networks. *Nature*, 165, 514-516.
2. Bar-Cohen Y., 2005, Biologically Inspired Intelligent Robots using Artificial Muscles, *Strain* 41, pp. 19-24.
3. Trujillo R., Mou J., Phelan P.E., Chau D.S., 2004, [Investigation of electrostrictive polymers as actuators for mesoscale devices](#), *Int J Adv Manuf Technol*, 23(3-4), pp. 176-182.
4. Lacour S.P., Pelrine R., Wagner S., Prahlad H., 2003, *SPIE-EAPAD Conf Proc* 5051, pp. 412-418.
5. Kornbluh R.D., Flamm D.S., Prahlad H., Nashod K.M., 2003, *SPIE-EAPAD Conf Proc* 5051, pp. 143-158.
6. Szabo J.P., Hiltz J.A., Cameron C.G., Underhill R.S., Massey J., White B. et al., 2003, *SPIE-EAPAD Conf Proc* 5051, pp. 180-190.
7. Pelrine R., Kornbluh R., Pei Q., Joseph J., 2000, High-speed electrically actuated elastomers with strain greater than 100%, *Science*, 287, pp. 836-839.
8. Ma W., Cross I.E., 2004, An experimental investigation of electromechanical response in a dielectric acrylic elastomer, *Appl Phys A*, 78, pp. 1201-1204.
9. Lacour S.P., Prahlad H., Pelrine R., Wagner S., 2004, Mechatronic system of dielectric elastomer actuators addressed by thin film photoconductors on plastic, *Sensors and Actuators A: Physics*, 111 (2-3), pp. 288-292.
10. Carpi F., Chiarelli P., Mazzoldi A., Rossi D., 2003, Electromechanical characterisation of dielectric elastomer planar actuators: comparative evaluation of different electrode materials and different counterloads, *Sensors and Actuators A: Physics*, 107, pp. 85-95.
11. Pei Q.B., Pelrine R., Stanford S., Kornbluh R., Rosenthal M., 2003, Electroelastomer rolls and their application for biomimetic walking robots, *Synth Met* 135/136, pp. 129-131.
12. Pei Q.B., Rosenthal M., Pelrine R., Stanford S., Kornbluh R., 2003, *SPIE-EAPAD Conf Proc* 5051, pp. 281-290.
13. Kornbluh R., Pelrine R., Joseph J., Heydt R., Pei Q.B., Chiba S., 1999, *SPIE-EAPAD Conf Proc* 3669, pp. 149-161.
14. Zhang Q.X., Wissler M., Jähne B., Brönnimann R., Kovacs G., 2004, *SPIE-EAPAD Conf Proc* 5385, pp. 78-86.

15. Michel S., Zhang X.Q., Wissler M., Löwe C., Kovacs G., 2009, A comparison between silicon and acrylic elastomers as dielectric materials in electroactive polymers actuators, *Polym Int.*
16. Visser S.A., Hergenrother R.W., Cooper S.L., 1996, Polymers, chapter in Biomaterials Science: an introduction to materials in medicine, Edited by Buddy D. Ratner et al. (Elsevier Academic Press), pp. 50-60.
17. Yim E.K., Reano R.M., Pang S.W., Yee A.F., Chen C.S., Leong K.W., 2005, Nanopattern-induced changes in morphology and motility of smooth muscle cells, *Biomaterials* 26, pp. 5405-5413.
18. Toworfe G.K., Composto R.J., Adams C.S., Shapiro I.M., Ducheyne P., 2004, *J. Biomed. Mater. Res.* A71, pp. 449-461.
19. Yamada N., Yoshinaga I., Katayama S., 2000, Formation behavior and optical properties of transparent inorganic-organic hybrids prepared from metal alkoxides and polydimethylsiloxane, *Journal of Sol-Gel Science and Technology*, 17, pp. 123-130.
20. Rojas-Cervantes M.L., López-Peinado A.J., Martín-Aranda R.M., Gómez-Serrano V., 2003, Synthesis and characterization of $x\text{TiO}_2(1-x)\text{SiO}_2$ -carbon composites, *Carbon*, 41, pp. 79-86.
21. Pēna-Alonso R., Téllez L., Rubio J., Rubio F., 2006, Surface chemical and physical properties of TEOS-TBOT-PDMS hybrid materials, *Journal of Sol-Gel Science and Technology*, 38, pp. 133-145.
22. Akinci A., 2009, Mechanical and morphological properties of basalt filled polymer matrix composites, *Archives of Materials Science and Engineering*, 35, pp. 29-32.
23. Wang X.X., Wang H.T., Song X.M., Wang G.Q., Chen Q.T., 2010, Photovoltaic polymerization induced by a transparent anatase titania aqueous sol and fabrication of polymer composites, *eXPRESS Polymer Letters*, 4, pp. 373-381.
24. Monson T. C., Huber D. L., 2008, High refractive index TiO_2 nanoparticle silicone composites, in Physical, chemical, and nano sciences center research briefs 2008, Sandia National Laboratories Albuquerque.
25. Cazacu M., Ignat M., Racles C., Vlad A., Alexandru M., Zarnescu G., 2009, Polydimethylsiloxane/silica composites incorporating pyrite powders for actuation elements, *Polymer International*, 58, pp. 745-751.
26. Cazacu M., Ignat M., Vlad A., Alexandru M., Zarnescu G., 2010, Heat-cured silicone rubber incorporating pyrite powders for actuation elements, *Optoelectronics Advanced Materials Rapid Communication*, 4, pp. 349-351.
27. Alexandru M. et al., 2010, Polydimethylsiloxane /silica/titania composites prepared by solvent-free sol-gel technique, *J Sol-Gel Sci Technol*, 56, pp. 310-319.
28. Alexandru M. et al., 2011, On the morphology and potential application of polydimethylsiloxane-silica-titania composites, *eXPRESS Polymer Letters*, Vol.5, No.2, pp. 188-196.
29. Valenta L., Bojtos A., 2008, Mechanical and electrical testing of electrically conductive silicone rubber, *Materials Science Froum*, vol. 589, pp. 179-184.
30. Scoot O.N., Begley M.R., Komaragiri U., Mackin T.J., 2004, Indentation of freestanding circular elastomer films using spherical indenters, *Acta Materialia* 52, pp. 4877-4885.
31. Cârlescu V., Olaru D., Breabăn F., Prisăcaru Gh., 2011, Comparative study of electromechanical response in some dielectric elastomers, *Journal of Optoelectronics and Advanced Materials*, Vol. 13, Nr. 8, pp. 986-991.
32. Breabăn F., Cârlescu V., Olaru D., Prisăcaru Gh., 2011, Laser scanning vibrometry applied to non-destructive testing of electroactive polymers, *U.P.B. Sci. Bull.*, Series D, vol. 73, Iss. 2, pp. 171-180.