

## **Etalbond Aluminium Composite Material for Metallic Constructions**

Drd. Eng. **Marian Alexandru PETREA**,  
PhD. Eng. **Gheorghe OPREA**  
"Technical Military Academy" of București,  
Romania

### **Abstract**

*Etalbond is a sandwich – type composite panel consisting of a non-toxic polyethylene core firmly bonded between fine aluminum facing and backing sheets. The bonding of aluminum sheets with the core is realized with simultaneous application of mechanical and chemical methods under high temperatures. The final stage of production offers a strong and exceptionally rigid flat sheet of composite panel of which the total thickness can vary from 3 to 6 mm used mainly in building exterior and interior design. In the paper are presented the main advantages of using etalbond sheets, and some aspects regarding the selection of support systems which dictate different types of manufacturing and assembly technologies.*

**Keywords:** composite panel, composite material, building design, metallic construction

### **1. Introduction**

The development of the metallic construction from his beginning and the tendency of future development can be follow only if we study the next factors witch characterizes the technical and the economic influence: the quality of the material, the constructive structure, the calculation methods and the execution and assembling technology.

The metallic constructions appears after the half of the XVIII century, in 1779, when the first metallic road bridge made from cast iron was open, in England, over the Severn river. After the year 1880, in all technical domains, especially in metallic construction domain, the steel has replaced the cast iron.

After some time, at the beginning of the XX century, once with the towns fast development, has appear the necessity of making buildings with many floors witch structure are made from steel and having closing realized with the help of classic solutions: masonry plus glass or metal plus glass.

Because the execution technology are of special proportion, in time it was search like usual solutions for the metallic construction closing that these ones to be realized in the must simple way possible, having the minimum weight and having a nice architecture not only in vertical disposing but also in horizontal disposing.

How it is known, the conservation of the natural environment is a problem of maximum importance. Each one exterior construction requests a special approach of this problem.

The access points on the thoroughfares and in the petrol stations, the industrial buildings and tunnels – all this ones must be integrated in the natural environment.

Among the materials and the new technology used for making the metal constructions and for solve the previous problems, in the last time, an important part is occupied by the etalbond-composite panel, sandwich" type.

### **2. Etalbond structure and process**

The raw materials used in the etalbond production are: aluminum sheet, 0.50 or 0.30 mm of thickness in the form of coils, polyethylene and a special adhesive in pellet form (figure 1).

The production process of etalbond is schematically shown in figure 2. The melted plastic is blended with a special adhesive and leaks between the two aluminum sheets. The three parts (two aluminum sheets and adhesive along with polyethylene) are highly compressed within the rolls resulting in a rigid and durable material.

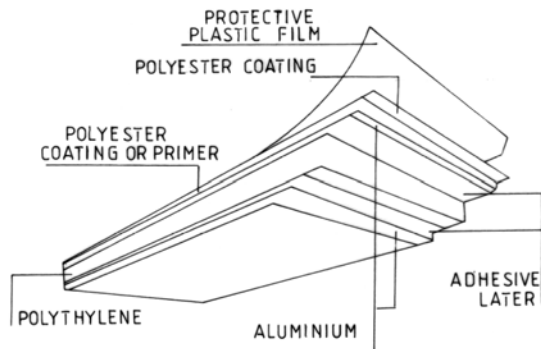

Fig. 1. Etalbond structure

The main advantages that etalbond offers, whose unique features facilitate the supplant of the traditional constructive materials, are:

- **In spite of its lightness is exceptionally strength;**
- **Elevate rigidity;**
- **Simple forming technique:** Routing and folding can even be performed on site. It can be easily worked into a variety of shapes. Due to its lightness reducing frame lodgings - cost of fabrication and installation;

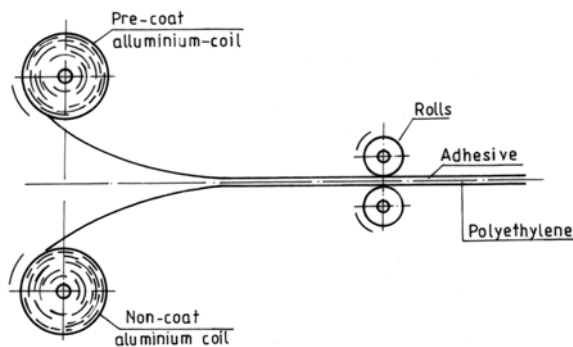

Fig. 2. Etalbond production process

- **Short time for mounting:** Like a result is the short cut for the construction time;
- **Resistant to extremes of weather exposure and temperature:** The most accreditate international organizations certify the resistance capability of this material to the most severe conditions;
- **Easy maintenance:** The clearance of the panels can be done with a soft detergent due to the smooth, monolithic surfaces that creates;
- **Appearance:** Curved and multiplanar surfaces in striking colours create a new elegance in buildings and constructions of all kinds. Attractive and versatile, etalbond is the ideal cladding for interior and exterior surfaces on new constructions and renovations.

### 3. Applications

- Architectural Claddings
- Internal Wall coverings
- Building Renovations
- Internal Partitions
- False ceilings
- Gas Stations
- Highway Toll Stations
- Internal Decoration
- Signage
- Exhibition Stands
- Bus terminals
- Container constructions
- Machine Coverings

### 4. Selection of Etalbond support systems

The selection of an outer covering suitable support system with cassettes has to be realized at the phase of the architectural designing, and after serious study.

This means that the structural engineer or architect should have considerable experience on architectural cladding subjects with respect to aluminium constructions. The system it is going to propose has to fulfill the peculiarities of construction stability and the aesthetic demands in combination with the building demands for more flexible and economical solutions that maintain construction easiness and technical performance (figure 3).

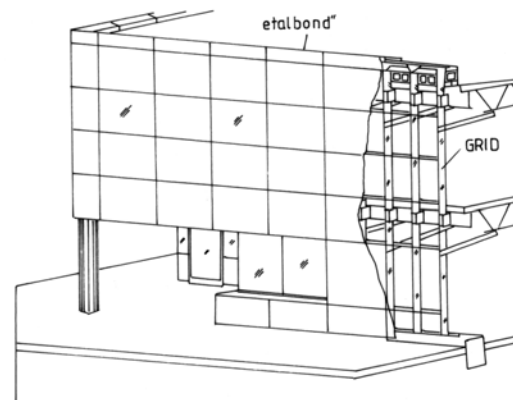

Fig. 3. Etalbond construction

The industries that produce composite panels in large scale usually propose their own support system, while various other construction enterprises in the field of architectural cladding propose their own support systems.

Consequently with regards to the selection of the support system there is not only a vast amount of information, but there is also and the equivalent field experience. The various support system in existence can cover almost any construction demand.

ETEM drawing from its experience on a multitude of construction projects in Greece and elsewhere proposes its own support systems along with the equivalent technical information that accompany them.

The many years of experience in the construction field and the architectural aluminium applications are combined in the most efficient way on the architectural cladding applications using Etalbond composite aluminium panels.

### Selection of the support system

Independently from the system of support that is going to be selected, each work must dispose indispensably: flat profile (all cassettes must be on the same level); straightness of the vertical and the horizontal seams (scotias); perfect appearance and link at the inserted positions respecting the various openings (e.g. windows, windowpanes etc.), as well as and the “finishing” (or the projections) for instance parapets, balconies etc.

Besides the appearance, there are many other factors, that can characterize the applicable etalbond support system each times, as :

- The watertightness,
- The possibility of intervention respecting the restitution of any fault or damage during construction, damage during positioning, or after the completion of the work.

- Durability against corrosion,
- Interventions respecting the appearance of the building.

The success of support system depends on:

- The study, the design, and the organization respecting the project materialization.

- The contractor’s knowledge level.
- Contractor’s experience with respect to the specific system.

- The gear respecting the construction of work.
- The **controlling gear**, during the construction of the work.

- The accurate application of the system as it is designed, without any occasional inventions, artless reproductions and “seeing and acting” techniques.

- In case that the selected system it is accompanied from some **precision** fixtures or profile, then those original parts must be **indispensably** used by the supplier.

- The applied corrected actions when ascertained that there are application problems.

- From the above mentioned it is rendered obvious that, the contractor has the exclusive responsibility respecting the quality of cladding work either for the proposed by himself system, or any assigned cladding system, accepted by the contractor.

**The Etalbond support systems are classified in:**

- Systems of support for simple panels

- Systems of support for the shaped panels in “Box shaping” or cassettes.

### Support systems for Etalbond panels;

ETEM disposes equivalent systems; several of them accompanied by the special profiles, which have been developed for this purpose. There is more information in the following drawings.

### Support system for cassettes;

The support of the cassettes it is possible to be realized with the following manners:

- Support with suspending (hanging) of the cassette on the vertical carriers of the related sub-structure.

- Support of the-cassettes with bolts or rivets on the related sub-structure, (grid), with the support of various components.

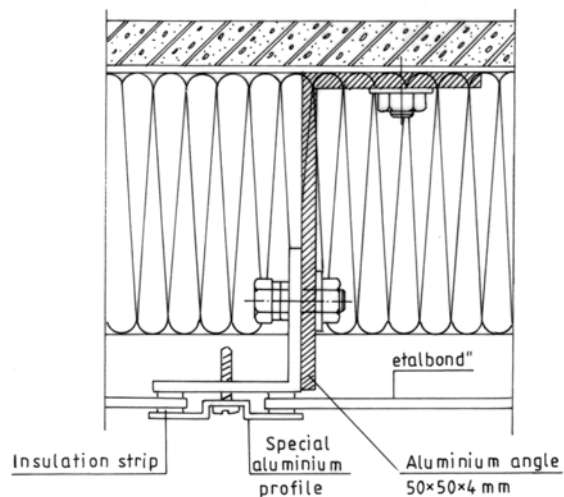

Fig. 4. Support system with bolts or rivets

- Support system with hanged cassettes;

The principle of the system appeared in figure 5.

The origin of the hanged cassette derived from the systems disposed by the compact aluminium plates manufacturing companies that of course pre existed of composite panels.

The hanged cassette system is available in many types (various support system manufacturers). Each manufacturer proposing its own support system.

*Advantages:*

- The positioning of the ready-made cassette is a fast procedure which means low labor cost and short delivery time of the work.

- It is possible to realize seams (scotias) of small width, with a low labour cost.

- As much as the preparation of the sub-structural support grid and the cassette manufacturing have no deviations, so the quality is very good.

- The sub-construction support is focused nearly exclusively at the positioning of the vertical carriers on which the cassettes hanged through the side hooks.

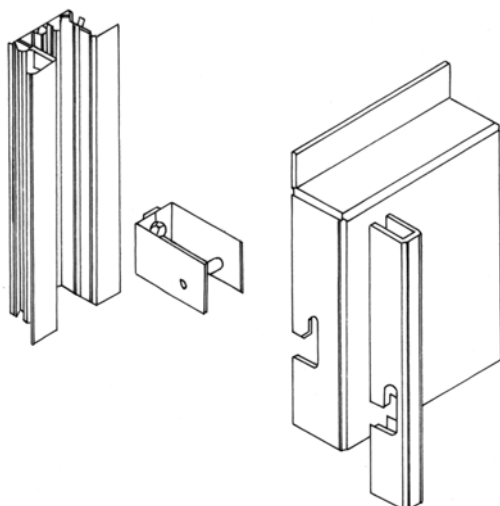

Fig. 5. Support system with hanged cassettes

*Remarks about the system of the hanged cassette:*

- It is obvious, that contractor's experience, the level of the available mechanical gear, the drawing department and other factors, play a decisive role respecting the final quality of construction. For this reason, the previous experience of cladding contractor must be taken into account seriously, respecting the constructions of the cassette.

- System of support with marginally riveted angles on the iron sub-construction;

In the drawings of the previous pages, we observed the principle of the above mentioned system

of support, and the covering with strip from etalbond, that is welded with SIKAFLEX 252 (single component elastomeric polyurethane), or with silicone.

*Advantages:*

- The system is simple, so much respecting the construction, as and the preparation of the cassette.

- The iron sub-construction (grid) could be prepared and controlled with a great easiness. Nevertheless, any change could be corrected, in the space of the work locally.

- The support of the cassettes and the correct position it could be controlled very easy and the restitution of mistakes is exceptionally simple.

- Even-though the constructor has a little experience; it is possible the quality of the work be secured, since are possible any corrections or interventions, till the completion of construction.

- The covering is tight. The work respectively to the "finishing" is easy and it is absolutely controlled.

## 5. References

[1] "Etalbond"- Aluminium composite material – TEHNICAL MANUAL – ETEM

[2] C., Dalban, E., Chesaru, *Metalic Constructions and Structure* - Editura Tehnică – 1997

[3] D., Mateescu, L., Gădeanu, *Metalic Constructions* – Editura Tehnică – 1975

[4] P., Siminea, L., Negrei, *Metalic Constructions and The Execution Technology* - Editura Tehnică – 1975

[5] A.Trelea, *The Technology Of Constructions Work* – Editura Tehnică – 1980

## ETALBOND, MATERIAL COMPOZIT DIN ALUMINIU PENTRU CONSTRUCȚII METALICE

### Rezumat

Etalbond-ul reprezintă un panou compozit de tip sandwich, compus dintr-un miez netoxic din polietilenă, cu grosimea cuprinsă între 2 și 5 mm, fixat solid între două foi de aluminiu cu grosimi de 0,5 mm. Adeziunea tablelor de aluminiu cu miezul se face prin aplicarea simultană a unor metode mecanice și chimice la temperaturi înalte. Etapa finală a producției asigură un panou compozit din tablă excepțional de rigidă a cărui grosime variază între 3 și 6 mm, utilizat în design-ul de exterior și interior al clădirilor. În lucrare se prezintă principalele avantaje ale utilizării tablelor etalbond, și câteva aspecte legate de alegerea sistemelor de prindere care dictează diferite tipuri de tehnologii de fabricare și asamblare.

## ETALBOND, D'ALUMINIUM PANNEAU COMPOSIT POUR CONSTRUCTION MÉTALLIQUE

### Résumé

Etalbond est un sandwich - type panneau composé se composant d'un noyau non-toxique de polyéthylène fermement collé entre les revêtements d'aluminium et les feuilles fins de support. La liaison des feuilles d'aluminium avec le noyau est réalisée avec l'application simultanée des méthodes mécaniques et chimiques sous les températures élevées. L'étape finale de la production offre une feuille plate forte et particulièrement rigide dont de panneau composé toute l'épaisseur peut changer de 3 à 6 millimètres utilisés principalement dans le bâtiment extérieur et la conception intérieure. Dans le papier sont présentés les avantages principaux d'employer des feuilles d'etalbond, et quelques aspects concernant le choix des systèmes de soutien qui dictent différents types de technologies de fabrication et d'assemblage.